



Manual for installation,
use and maintenance

MHG101SS

Gas hob

Contents:

- 3 Important
- 5 Important Notes
- 6 Using Your Hob
- 7 Igniting the burners
- 9 Efficient use of your hob
- 10 Care And Maintenance
- 11 Troubleshooting
- 12 What to do if you smell gas
- 15 Mains Electricity Connection
- 16 Technical Information
- 17 Gas Supply Requirements
- 18 Ventilation
- 18 Natural Gas to LPG Conversion
- 19 LPG to Natural Gas Conversion
- 20 Fitting the hob
- 21 How to install the hob
- 22 Installation diagrams

Important

The CDA Group Ltd cannot be held responsible for injuries or losses caused by incorrect use or installation of this product. Please note that CDA reserve the right to invalidate the guarantee supplied with this product following incorrect installation or misuse of the appliance or use in a commercial environment.

This appliance is not designed to be used by people (including children) with reduced physical, sensorial or mental capacity, or who lack experience or knowledge about it, unless they have had supervision or instructions on how to use the appliance by someone who is responsible for their safety.

Under no circumstances should any external covers be removed for servicing or maintenance except by suitably qualified personnel.

Appliance information:

Please enter the details on the appliance rating plate below for reference, to assist CDA Customer Care in the event of a fault with your appliance and to register your appliance for guarantee purposes.

Appliance Model	
Serial Number	

EU Declarations of Conformity

This appliance has been manufactured to the strictest standards and complies with all applicable legislation, including Electrical safety (LVD) 2014/35/EU and Electromagnetic interference compatibility (EMC) 2014/30/EU. Parts intended to come into contact with food conform to 1935/2004/EC.

IMPORTANT INFORMATION FOR CORRECT DISPOSAL OF THE PRODUCT IN ACCORDANCE WITH EU DIRECTIVE 2012/19/EU.

At the end of its working life, the product must be taken to a special local authority waste collection centre or to a dealer providing appliance recycling services.

Disposing of a household appliance separately avoids possible negative consequences for the environment and health. It also enables the constituent materials to be recovered, saving both energy and resources. As a reminder of the need to dispose of household appliances separately, the product is marked with a crossed-out wheeled dustbin. 

Important Notes

Please note:

- Gas hobs become hot and remain hot during and immediately after use. We strongly advise that you do not touch the hob, nor any of its components, until it has been allowed to cool. If wiping away a spillage, please take every care not to burn yourself.
- Keep children away from the appliance when in use.
- After use, ensure the control knobs are in the off position.
- Never use the hob top for storage.
- Pan handles should never stand out beyond the edge of the worktop. This will help to ensure children cannot reach them.
- Ensure that the appliance is correctly adjusted for the type of gas available before installation.
- The use of a gas appliance produces heat and humidity in the room in which it is installed. Ensure that the room is well ventilated, either by the use of natural ventilation outlets (e.g. windows) or an externally ducted extractor.
- Do not lean over the hob when it is in use.
- Follow the cleaning instructions carefully.
- Ensure the base of any saucepan is clean and dry before placing it on the hob.
- This hob (Class 3) has been designed for use only as a cooking appliance. Any other use (e.g. heating rooms) should be considered incorrect and therefore dangerous.
- The appliance is not intended to be operated by any means of an external timer or separate remote-control system.

This hob is a Class 3 appliance.

Using your hob



Fig.1

Gas Burners

- | | |
|----------------------------|--------|
| 1. Rapid burner | 3.0kW |
| 2. Left Semi-rapid burner | 1.85kW |
| 3. Right Semi-rapid burner | 1.85kW |
| 4. Auxiliary burner | 1.0kW |

Control knobs

- 5. Back right
- 6. Back left
- 7. Front left
- 8. Front right

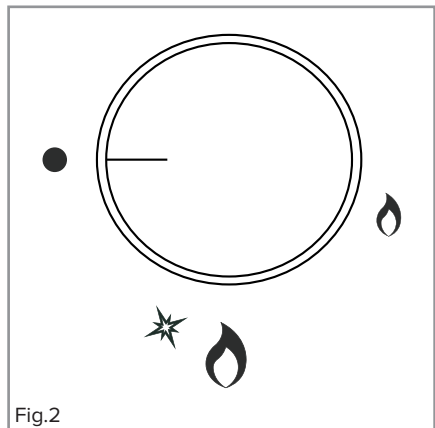



Fig.2

Gas burners

Gas flow to the burners is controlled by the control knobs (5,6,7 and 8 on Fig.1). There are 3 positions shown on the control panel (Fig.2). Turning the control knob to the positions shown below achieves the following:

- Closed (switches gas valve and burner off)
-  Maximum position (highest heat level) & ignition position
-  Minimum position (lowest heat level)

The knobs should always be turned in an anticlockwise direction from the closed/off position. Attempting to ignite the burner in a clockwise direction from the closed position may cause damage to the hob.

Igniting the gas burners

This hob's burners are fitted with flame failure devices. These operate by shutting off the gas supply to the burner in the event that the flame is extinguished whilst the control knob is in an open position.

To ignite the burners

Press the control knob down and turn the knob anticlockwise to the maximum position (Fig. 3). Hold the control knob down to begin the ignition process (a constant clicking should be heard). Once the flame appears around the burner, keep the control knob pressed down for a few seconds to allow the flame failure device to detect

the presence of the flame.

Once lit, release the control knob and turn it to the desired position i.e. until the burner flame is at the required intensity.

Once you have finished cooking with the burner(s) in use, return the control knobs to the closed (off) position.

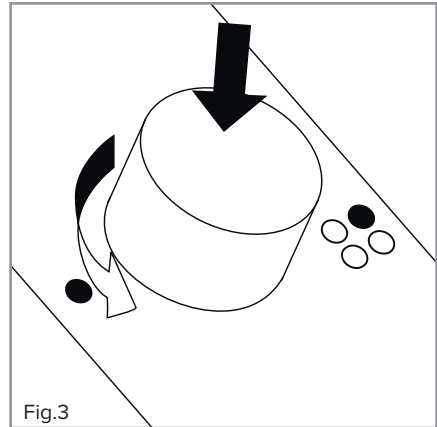

Please note:

The ignition should not be operated (clicking constantly) for more than 15 seconds at a time.

If a burner does not ignite, or turns off accidentally, turn the control knob to the closed (off) position. Wait for one minute before attempting to reignite the burner.

If the burner does not ignite, repeat the ignition process with the control knob at the minimum position.

If a burner continues to not ignite, please follow the troubleshooting section on page 11. If the burner has been in use recently, allow it to cool sufficiently before handling it.

Efficient use of your hob

The hob is equipped with burners of different sizes, designed to accommodate most sizes of pan. For best results, only use pans with flat bottoms and choose an appropriate burner depending on the size of the pan. The most efficient use of the hob is shown below, where the pan and burner are correctly chosen.

Use pan lids where possible to minimize the energy usage of your appliance.

Ensure that the pans do not overlap the edges of the pan stands, nor cover the control panel.

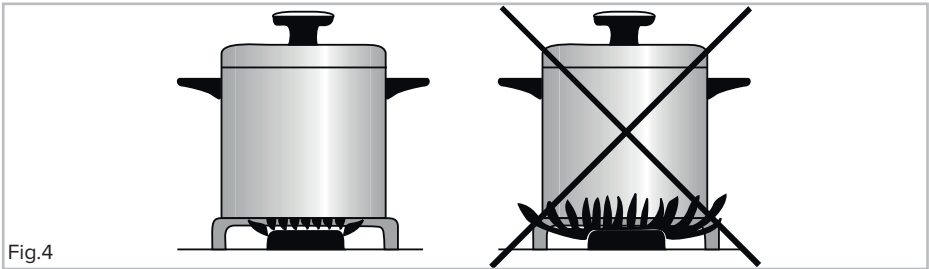

Fig.4

Burner	Minimum Pan Diameter (cm)	Maximum Pan Diameter (cm)
Auxiliary	12	14
Semi-Rapid	14	20
Rapid	18	24

Care and maintenance

The hob has a stainless steel surface. Due to this you should use a non-abrasive cleaner. Any abrasive cleaner (including Cif) will scratch the surface and could erase the control panel markings. Stainless steel can be effectively cleaned by simply using a dilute solution of water and washing up liquid and drying to a shine with a clean cloth.

Over time with use, the stainless steel surface may discolour; this is normal and does not constitute a fault with this appliance. Proprietary stainless steel cleaners are available.

The enamelled parts of hobs (pan stands and burner caps on this model) are not suitable for cleaning in dishwashers. They should be washed by hand and dried thoroughly afterwards with a clean, dry cloth.

IMPORTANT:

Steam cleaners must not be used when cleaning this appliances.

Ensure that all parts are correctly replaced after cleaning and before attempting to use the hob.

After removing the pan stands, ensure the rubber feet on the undersides are in place and not contaminated with dirt/grit before replacing the pan stands.

If water enters the ignition candle area, this can cause them to click constantly. This is not necessarily a fault. Switch the mains power supply off and wait for the water to dry up.

Troubleshooting

IF YOUR HOB IS NOT WORKING:

1. Check that the mains supply has not been switched off.
2. Check that the fuse or circuit breaker has not blown/tripped.
3. Check that the burner crowns and caps are fitted correctly and are not impeding the ignition candles or the flame failure devices (circled in Fig. 5).



4. Check that the burner caps (black metal plates that sit atop the burners) are clean and free from grease and debris on both sides.

IMPORTANT: Ensure burners have been allowed to cool before handling them.

If one or more burners continue to malfunction, please contact CDA Customer Care. Contact details can be found below.

A: Customer Care Department, The CDA Group Ltd, Harby Road, Langar,
Nottinghamshire, NG13 9HY

T: 01949 862 012

F: 01949 862 003

E: customer.care@cda.eu

W: www.cda.eu

WHAT TO DO IF YOU SMELL GAS:

1. Turn off the gas.

For **natural gas** -

Turn off the gas supply at the meter situated at the emergency control valve (ECV) unless the meter is located in a basement or cellar. If there is a smell of gas in the basement or cellar, evacuate the building.

For **Liquefied Petroleum Gas (LPG)** -

- **Bulk storage supply** - shut off the ECV outside the building and the gas isolation valve on top of the above-ground storage vessel(s), or underground storage vessel(s).
- **Metered installations** - shut off the ECV at the meter installation outside the building.
- **Cylinder fed installations** - shut all cylinder valves.

2. Extinguish all naked flames.

Do not smoke, ignite a lighter of any kind or strike matches.

3. Do not operate electrical switches

Turning a light on or off, or activating any kind of switch or socket outlet, can ignite escaping gas.

4. Open windows and doors

This gets rid of gas by ventilating the property. For LPG, ventilate at low level (LPG is heavier than air).

Please note: If gas is evident externally, consideration should be given to preventing gas entering the property (close windows and doors etc.).

5. Call the Gas Emergency Contact Centre

In the case of natural gas, contact the Gas Emergency Service Provider (ESP) or, in the case of LPG, the Gas Supplier. Below is a list of ESPs relevant to region:

England, Scotland and Wales:

Natural Gas - 0800 111 999 (Gas Emergency Contact Centre)

LPG - Bulk and Metered supplies - See telephone number on bulk storage vessel or at the meter.

LPG - Cylinder supplies - See gas supplier emergency contact details in the local telephone directory or as identified on the cylinder(s). Please note that caravan park owners, hire boat owners, etc. may have their own responsibilities in the event of a gas leak, so always contact the relevant site owner/authority.

Northern Ireland:

Natural Gas - 0800 002 001 (Northern Ireland Gas Emergency Service)

LPG - Bulk and Metered supplies - See telephone number on bulk storage vessel or at the meter.

LPG - Cylinder supplies - See gas supplier emergency contact details in the local telephone directory or as identified on the cylinder(s). Please note that caravan park owners, hire boat owners, etc. may have their own responsibilities in the event of a gas leak, so always contact the relevant site owner/authority.

Channel Islands - Guernsey:

Mains Gas + LPG (mains gas in the Channel Islands is an LPG and air mixture) - 01481 749000 (Guernsey Gas Ltd.)

Channel Islands - Jersey:

Mains Gas + LPG (mains gas in the Channel Islands is an LPG and air mixture) -
01534 755555 (Jersey Gas Company Ltd.)

Isle of Man:

Natural gas and LPG - 0808 1624 444 (Manx Gas Ltd.)

Gas Emergency contact details for the four main suppliers of LPG in the British Isles are shown below:

Calor - 08457 444 999

BP - 0845 607 6118

Flogas - 0845 7200 100

Shell - 0870 7539 999

Please note: The CDA Group Ltd. makes no warranty about the content of this section and will not be held liable, under any circumstances, for any direct or indirect damages resulting from the use of this information. If you have any questions regarding gas and safe practice, contact the Gas Safe Register® using the below details:

Consumers - 0800 408 5500

Engineers - 0800 408 5577

Mains Electricity Connection

Warning! This appliance must be earthed.

This appliance must be connected to the mains power supply by a competent person using fixed wiring via a double pole switched fuse spur outlet, having a contact separation of at least 3mm in all poles, and protected by a 3A fuse. The switch must be positioned no further than 2m from the appliance.

We recommend that the appliance is connected by a qualified electrician, who is a member of the N.I.C.E.I.C. and who will comply with the I.E.T. and local regulations.

This appliance is not suitable for connection to a 13A plug or 13A supply.

Please note:

- The mains cable must only be replaced by a qualified electrician or service engineer and must be of equivalent or better rating (i.e. 0.75mm², HO5VV-F).
- This appliance is intended to be connected to the mains supply with a cable of cross section area 0.75 mm². A larger cable may not fit the terminal connections.
- The marking of the current rating of the fuse protecting this appliance should be marked on the socket outlet.
- Assembly and electrical connection should be carried out by specialised personnel.
- When installing this product we recommend you seek the help of another individual.

The wires in the mains lead of this appliance are coloured in accordance with the following code:

Green & Yellow = Earth

Blue = Neutral

Brown = Live

As the colours of the wires in the mains lead for this appliance may not correspond with the coloured markings identifying the terminals connecting to the fuse spur, proceed as follows:

- The wire which is coloured green and yellow must be connected to the terminal marked E (Earth) or coloured green.
- The wire which is coloured blue must be connected to the terminal marked N (Neutral) or coloured black.
- The wire which is coloured brown must be connected to the terminal marked L (Live) or coloured red.

Technical Information

Total rated gas input: 7.7 kW

Mains electrical voltage: 230-240Vac, 50Hz

Total rated electrical consumption: < 1 W

Burner Size	Nominal Rating (kW)	Simmer Rating (kW)	LPG Flow Rate (l/h ⁻¹)	
			G30	G31
Auxiliary	1.0	0.45	72.8	71.5
Semi-Rapid	1.85	0.68	134.6	132.2
Rapid	3.0	1.12	218.8	214.8

Gas Supply Requirements

IMPORTANT: THIS APPLIANCE MUST BE FITTED BY A GAS SAFE REGISTERED FITTER OR OTHER SUITABLY QUALIFIED PERSON.

- This installation must comply with the Gas Safety (installation and use) Regulations 1984.
- This appliance is category I12H3+ and is designed for use in the UK and Ireland. The installation must comply with the Gas Safety (installation and use) Regulations 1984.
- The CDA Group Ltd is not legally able to provide any assistance in the installation of gas appliances except to Gas Safe registered installers. Any Gas Safe registered fitter requiring help must provide their name, address and registration number. Information supplied will be validated before help is provided.
- In the event that this appliance is not installed in accordance with the above requirements, the appliance may be disconnected from the mains gas supply until any faults are rectified; this is a legal requirement.
- This appliance should be installed using 15mm copper pipe connected via a shut-off valve in an adjacent unit. The shut-off valve needs to be accessible in an emergency or for service purposes.
- This appliance must not be connected to a combustion gas recovery scavenging system
- The connection to the gas supply must comply with all current regulations in force.
- We are not legally able to offer advice on the installation of gas appliances to non Gas Safe registered personnel.

Ventilation

All rooms require a window, or equivalent (e.g. a door), which can be opened. Some rooms require a permanent vent in addition to a window (see below).

This unit must not be used in a room which is less than 5m³. The following table details the requirements based on the kitchen volume (DxWxH) in m³.

Room Volume (m ³)	Air Vent Required (cm ³)
5	100
6 to 10	50
6 to 11	No permanent vent required if a door opens to the outside
11 or more	None required

The above requirements also allow for use of a gas oven and grill. However, if there are any other fuel burning appliances in the same room, consult the relevant British Standard (BS5440) or GAS SAFE Document.

Natural Gas to LPG Conversion

This hob can be converted from natural gas to propane operation at a nominal inlet pressure of 37mbar, or butane operation at a nominal inlet pressure of 28/30mbar. This conversion must only be carried out by a competent person (i.e. a Gas Safe registered fitter).

Instructions to fit replacement injectors:

1. Disconnect the appliance from the gas and electrical supplies.
2. Remove burner components and pan supports.

Tools/parts required:

- 7mm AF nut spinner
- Replacement injectors
- LPG identity plate

- Remove the injectors and replace with the corresponding injector as shown in the table at the bottom of this page.

Setting up minimum flow rates:

- Remove the control knobs.
- Turn on the LPG supply, light the burners and turn the controls to the minimum position, as indicated by the small flame.
- Insert a 2.5mm screwdriver into the hole at the top of the tap and turn the adjustment screw fully clockwise as shown in fig. 6.

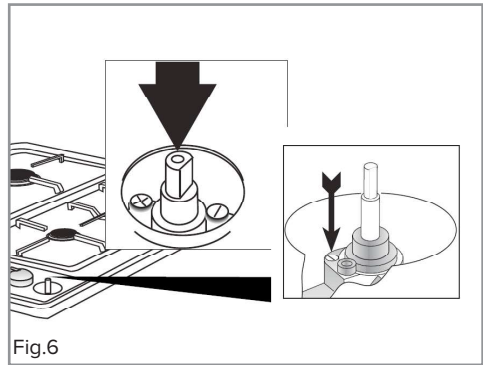

- Turn the controls to maximum position then quickly to the minimum position - make sure the flame does not extinguish.
- Replace the knobs.

LPG to Natural Gas Conversion

This hob can be converted from propane operation at a nominal inlet pressure of 37mbar or butane operation at a nominal inlet pressure of 28/30mbar to natural gas at 20mbar. This conversion must only be carried out by a competent person (i.e. a Gas Safe registered fitter).

Burner	LPG Injector	Natural Gas Injector
Rapid	86	118
Semi-Rapid	67	97
Auxiliary	49	72

Fitting the hob

Unpacking the hob:

Take care not to lose or mishandle any parts.

Fitting position of the hob:

This appliance must be installed a minimum of 150mm away from any adjacent vertical surfaces, e.g. a tall cupboard end panel. This may be reduced to 100mm if the adjacent surface is resistant to fire (tiles or steel, for example). These dimensions are shown in Fig. 7.

If fitting a cooker hood above the hob:

If a cooker hood is to be installed above the hob, the height of the hood above the hob must be at least 700mm (750mm is recommended) (Fig. 9). If the instructions supplied with the hood dictate that the hood must be installed at a height greater than 700mm, then that height is the minimum required.

Wall furniture requirements:

The minimum height of any cabinet immediately above the hob is 760mm. The minimum height of any adjacent units (including light pelmets) is 400mm, unless they are manufactured from a material resistant to fire (steel, for example).

Notes:

- Do not position this appliance above a refrigeration unit. The heat generated may cause the refrigeration unit to fail.
- This appliance is designed to be installed into cabinet units capable of withstanding temperatures 65°C above ambient or greater (typically 80-90°C).

- If there is no oven to be built in below the hob it is recommended that, an isolation shelf should be fitted to protect the user from high temperatures. If the hob is to be installed above a working drawer, then a partition should be fitted to protect the contents and user from the heat generated during use. This should be fitted at least 15mm below the hob. This panel should have a ventilation space at the rear of greater than 30mm as shown in fig. 7.
- Never place perishable foods in the cupboard below the appliance.

The rear wall or splashback the hob is to be fitted in front of must be made of a flame resistant material.

How to install the hob

Overall dimensions of the hob: Width: 580mm Depth: 500mm

Worktop cut-out dimensions: Width: 557mm Depth: 477mm

1. Make the required hole in the worktop. Note that before doing this, check the instructions supplied with any cooker hood to ensure that you will have the required clearance. The cut-out (Fig. 8) shows a 50mm gap from the wall or splashback, if fitted, to the cut-out edge.
2. Position the hob seal, as shown in the diagram on page 22 (Fig.10), ensuring that the ends meet without overlapping. **Do not use silicone type sealant**
3. This appliance must be installed to allow air to flow freely to the air intake and from the air outlet. The product's install depth is 50mm, which includes space for sufficient ventilation. Failure to allow sufficient ventilation could cause problems with operation or damage to the hob and constitutes incorrect installation, which is not covered by the product's warranty.
4. Secure the hob to the worktop using the fixing brackets and screws supplied, as shown in the following diagram (Fig. 11). Remove any excess sealant after tightening the brackets.

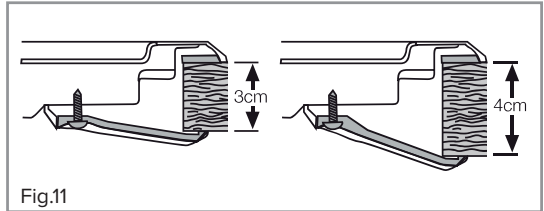
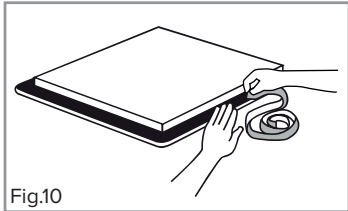
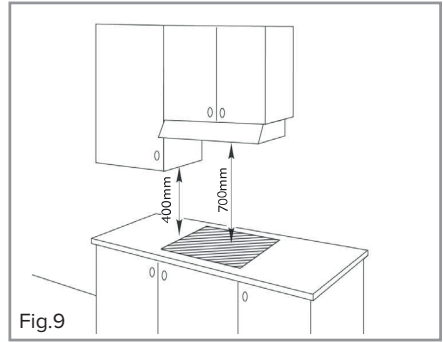
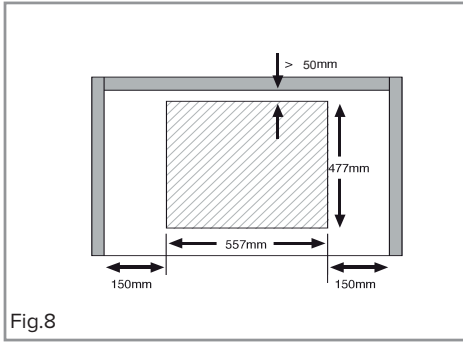
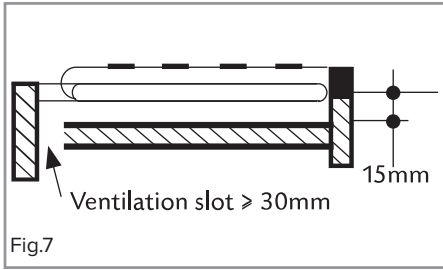

Energy Efficiency Information

Attribute	Symbol	Value	Units
Model Identification		MHG101	
Type of hob		Built in	
Number of gas burners		4	
Energy efficiency per gas burner	EE _{Gas burner}	Aux:NA / SR:55.5 / SR:55.5 / R:55.5	%
Energy efficiency for the gas hob	EE _{Gas hob}	55.5	%

A) Measurement and calculation methods

- The gas hob has CE approval according to the Gas Appliance Directives 2009/142/EC.
- The energy efficiency of this gas hob was tested and measured according to EN 30-2-1-1998+A1-2003+A2-2005.
- The semi-rapid burner and rapid burner were tested separately; the auxiliary burner is not required for test because its nominal heat input is less than 1.16kW.
- The energy efficiency of the gas burners and the hob were calculated according to COMMISSION REGULATION (EU) No.66/2014.

B) Rational use of the energy and the appliance

- The gas hob is designed for domestic use only, please do not use for commercial purposes.
- The gas hob is designed for use with gas (LPG and Natural gas). The combustion products contain carbon monoxide (CO) and carbon dioxide (CO²). These are affecting our environment.
- To ensure the rational use of energy, please install the gas hob according to the specifications in clause 5, and please make sure you are using the correct diameter of pan for each burner.
- To ensure safe use, please read this instruction manual before use; please follow the installation, operation and maintenance guidelines.
- To ensure the optimal life expectancy of the gas hob, please follow the operation and maintenance guidelines strictly; please do not modify the appliance.
- Please contact CDA Customer Care for repairing and exchanging of the components (such as gas valve, control knob) if necessary.
- The material of the gas hob is metal. Please dispose of the gas hob in recycling when the gas hob comes to the end-of-life.
- The packaging materials of this appliance are recyclable, please make good use of waste materials.

E & O E. All instructions, dimensions and illustrations are provided for guidance only. CDA reserve the right to change specifications without prior notice.



Serviced by



For service or queries relating to your product please contact

The Customer Care Department on **01949 862 012** or email customer.care@cda.co.uk

For more information please contact

The Sales Department on **01949 862 010** or email sales@cda.co.uk

Customer Care Department. The CDA Group Ltd, Harby Road, Langar, Nottinghamshire, NG13 9HY
T: 01949 862 012 F: 01949 862 003 E: customer.care@cda.co.uk