



Manual for installation,
use and maintenance

MHN101FR

Induction Hob



Important

The CDA Group Ltd cannot be held responsible for injuries or losses caused by incorrect use or installation of this product. Please note that CDA reserve the right to invalidate the guarantee supplied with this product following incorrect installation or misuse of the appliance or use in a commercial environment.

This appliance is not designed to be used by people (including children) with reduced physical, sensorial or mental capacity, or who lack experience or knowledge about it, unless they have had supervision or instructions on how to use the appliance by someone who is responsible for their safety.

Under no circumstances should any external covers be removed for servicing or maintenance except by suitably qualified personnel.

Appliance information:

Please enter the details on the appliance rating plate below for reference, to assist CDA Customer Care in the event of a fault with your appliance and to register your appliance for guarantee purposes.

Appliance Model	
Serial Number	

EU Declarations of Conformity

This appliance has been manufactured to the strictest standards and complies with all applicable legislation, including Electrical safety (LVD) 2014/35/EU and Electromagnetic interference (EMC) 2014/30/EU.

Parts intended to come into contact with food conform to 1935/2004/EC.

IMPORTANT INFORMATION FOR CORRECT DISPOSAL OF THE PRODUCT IN ACCORDANCE WITH EC DIRECTIVE 2012/19/EU.

At the end of its working life, the product must be taken to a special local authority waste collection centre or to a dealer providing appliance recycling services.

Disposing of a household appliance separately avoids possible negative consequences for the environment and health. It also enables the constituent materials to be recovered, saving both energy and resources. As a reminder of the need to dispose of household appliances separately, the product is marked with a crossed-out wheeled dustbin. 

Please note:

- Induction hobs become hot and remain hot during and immediately after use. Do not touch the hob until it has been allowed to cool.
- Keep children away from the appliance when in use.
- Never use the hob top for storage.
- Pan handles should never stand out beyond the edge of the worktop. This will help to avoid children reaching them.
- Do not lean over the hob when it is in use.
- Follow the cleaning instructions carefully.
- Ensure the base of the saucepan is clean and dry before placing it on the hob.
- Avoid hard shocks from cookware – the vitroceramic glass surface is highly resistant but not unbreakable.

- Do not place hot lids flat on the hob top. A “suction” effect could cause damage to the hob.
- Do not drag cookware across the hob top: in the long term, this could cause damage to the hob.
- Do not store cleaning or flammable products in the unit below the hob.
- Always use appropriate cookware.
- Do not cook unopened tins of food directly on the hob.
- Never put cooking foil or plastic materials on the ceramic surface when the hob is hot. These materials could melt and cause damage to the hob.
- This hob (Class 3) has been designed for use only as a cooking appliance. Any other use should be considered incorrect and therefore dangerous.

FOR THOSE WITH HEART PACEMAKERS OR ACTIVE IMPLANTS:

The function of this hob conforms to current electromagnetic interference standards and thus is in total compliance with legal requirements (2004/108/CE directives).

To avoid interference between your hob and a pacemaker, your pacemaker must be designed and programmed in compliance with the regulations that apply to it. As such, CDA guarantee only that our product is compliant.

With regard to the compliance of the pacemaker or any potential incompatibility, you should obtain information from the manufacturer or your attending physician.

Important

- Do not use the hob if the glass surface is cracked or damaged to prevent the risk of electric shock. Disconnect it from the power supply.
- Ensure that the power cable of a connected electrical appliance near the hob is not in contact with the cooking zones.

Cooking on Induction

The principle of induction cooking is based on magnetic effect.

When you put your cookware on an induction zone and switch it on, the electronic boards in the hob produce induced currents in the base of the cookware and instantly raise its temperature. This heat is then transferred to the food inside the cookware.

The best cookware to use with induction cooking has thick flat bases, as the heat will be better distributed meaning cooking is more even.

Most cookware is compatible with induction cooking.

There are three ways to check the suitability of your cookware:

1. Using a magnet to see if the base of the pan is magnetic: If the magnet sticks, then the cookware is compatible.
2. Place the pan on one of the cooking zones and switch the zone on. If the display continues to show the selected power level then the cookware is compatible. If the display shows “E”, the cookware cannot be used on an induction hob.
3. Check the instructions or packaging of the pans for the symbols indicating suitability for use with induction.

Using your hob

Zones:

1. Front left 2 - 3kW 220 mm
2. Back left 1.2 - 1.4kW 180 mm
3. Back right 2 - 3kW 220 mm
4. Front right 1.2 - 1.4kW 180 mm

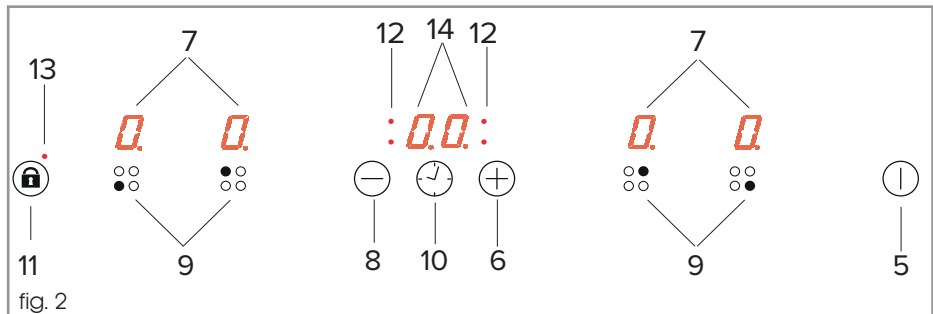
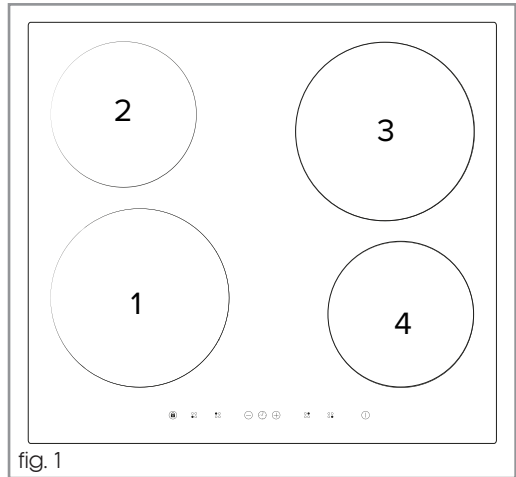

Control panel:

- | | |
|---------------------------------|-------------------------------------|
| 5. On/off sensor | 10. Timer sensor |
| 6. Higher heat setting selector | 11. Safety key lock sensor |
| 7. Cooking zone indicator | 12. Timer indicator light |
| 8. Lower heat setting selector | 13. Safety key lock indicator light |
| 9. Cooking zone selector(s) | 14. Timer display |

Using your hob

To switch the hob on

- To switch the power on, touch and hold the "On/off sensor" (5) ① for approximately two seconds. The hob will beep and all four cooking zone indicators will show "0".

Please note: If a zone is not selected nor a power level set within ten seconds, the hob will switch off automatically.

To set the power level

- Touch the cooking zone selector (9) for the required zone. The hob will beep and the zone display will show a pulsating "0" on the selected zone's indicator.
- Select the desired heat setting using the "+" or "-" selectors. The power level ranges from 1 (minimum) to 9 (maximum). The hob will begin heating and the cooking zone indicator will pulsate for approximately ten seconds before remaining solidly lit. Inactive cooking zones' indicators will dim at this point.
- This hob also has a "Keep warm" function as well as a "Booster" function. The "Keep warm" function is available between "0" and "1" heat settings and is shown on a cooking zone indicator as "L". The Booster function is available after heat setting "9" and is shown on a cooking zone indicator as "P".

Please note: After zone selection, the zone will remain active for approximately ten seconds. If no key is touched during this time, the zone will become inactive and the hob will switch off automatically.

To turn the power off to a zone

- To switch off a zone, touch the cooking zone selector (9) so that the cooking zone indicator (7) pulsates. Then press and hold the cooking zone selector (9) for approximately three seconds. The cooking zone indicator will display a "0" to confirm that the zone is now inactive but will display an "h" or "H" if the zone is still hot to the touch.
- If switching off multiple zones, the above step needs to be taken for each zone. When all the zones are at "0", the hob will switch off automatically after approximately ten seconds.
- Alternatively, to switch off the hob immediately, touch and hold the "On/off sensor" (5) ① for approximately two seconds. Any zones that are still hot to the touch will display an "h" or "H".

Booster function

- The hob is equipped with a booster function on all zones, allowing a higher power level than the maximum for approximately ten minutes. To turn on the booster function, touch the cooking zone selector (9) for the desired zone, set the heat setting to "9" using the "+" sensor (6) and then touch the "+" sensor (6) once more. "P" will show in the cooking zone indicator to show that the booster is on.
- The booster function automatically deactivates after 10 minutes of usage. The cooking zone will continue to operate at its nominal power at this point. The booster can be reactivated after this time provided the hob's internal components have not overheated.
- To cancel the booster at any time, select the cooking zone using the cooking zone selector (9) and lower the heat setting using the "-" sensor (8).

Please note: The booster function cannot be used on two vertically arranged cooking zones at the same time. This is to prevent damage to the internal modules caused by overheating.

If the appliance's electronic circuits or induction coils overheat whilst the booster function is in operation then the function will be automatically deactivated and the zone will continue to operate at its nominal power. The booster function will be available again once the internal components have been cooled sufficiently.

It is normal for a high pitched whirring noise to begin whilst the booster function is in use. This is the cooling fan inside the hob keeping the internal components as cool as possible.

If a pot is removed from the cooking zone whilst the booster function is in use, the function remains active and the ten minute countdown continues.

Operating time limiter

In addition to the booster deactivation timer, each zone has an operating time limiter to increase overall efficiency and to prevent the hob from being left on indefinitely. If a zone's heat setting is not changed for a specific duration then the associated zone is automatically switched off and residual heat indicator activated. Zones can still be used as normal in accordance with the operating instructions. The operating time limiter is set according to the last selected heat setting. The maximum operating times for each setting can be found on page 11.

Operating time limiter durations

Zone heat setting	Maximum operating time (minutes)
L	480
1	480
2	480
3	300
4	300
5	300
6	90
7	90
8	90
9	90
P	10

Auto-Heat function

- Every zone is equipped with an auto-heat function, which reduces the warming up time for the zone. To turn on the auto-heat function, touch the cooking zone selector (9) for the required zone, then set the desired heat setting using the "+" sensor (6).
- With the cooking zone indicator (7) still pulsating, touch the cooking zone selector (9) for that zone for approximately one second. The display will alternate between the set power level and "A" for a preset period of time, before reducing the power to the originally selected heat setting.
- To disengage the auto-heat function simply select the zone using the cooking zone selector (9) and then press the cooking zone selector (9) again for approximately one second.

Timer/Minute Minder

The hob is equipped with a timer that allows a finish time to be set for the end of cooking on any zone, between a minimum of 1 minute and a maximum of 99 minutes. This timer can be used separately for each zone, and an LED will indicate the zone positions for each of the active timers. Once the timers are set, the timer display will show the time remaining on the first zone to finish cooking. The timer can also be used as a minute minder to count down time, when the zones are not in use.

To set the timer

- First switch on the hob and set the desired zone to the power level required.
- Whilst the relevant cooking zone indicator (7) is pulsating touch the timer sensor (10). Using the higher heat setting selector (6) or the lower heat setting selector (8), set the desired cooking time (in minutes) to between 0 and 99. The selection will confirm in approximately 2 seconds, the timer display will show the time set and the countdown will start.
- If no time is set within ten seconds, the timer indicator light (12) will become inactive and the zone will continue cooking.

At the end of the timer, the selected zone will switch off and the timer display, and relevant time indicator light, will flash. The hob will beep for approximately two minutes. To switch off the beep and the flashing displays, touch any key. This beeping also occurs after the minute minder time has elapsed and the same process to switch off the beep applies.

Please note: The timer duration can be adjusted at any time during the countdown. Simply touch the relevant cooking zone selector (9) so that the zone indicator (7) pulsates, then press the timer sensor (10) within 10 seconds and adjust the minutes using the higher (6) and lower (8) heat setting selectors.

Please note: The power level can be adjusted at any time during the countdown.

To cancel the timer

- Touch the cooking zone selector (9) for the required zone so that the cooking zone indicator (7) pulsates. Touch the timer sensor (10) and hold it for approximately 3 seconds.

Please note: Cancelling the timer will not switch off the zone. You should switch the zone off manually if required.

To set the minute minder

The timer can also be used as a minute minder when the hob is not in use.

- Switch the hob on using the on/off sensor (5).
- Touch the timer sensor (10) to activate the minute minder.
- Use the higher (6) and lower (8) heat setting selectors to set the desired time in minutes.

To cancel the minute minder

- Touch and hold the timer sensor (10) for approximately 3 seconds.

Keep Warm function

Each zone is equipped with a keep warm function that is designed to keep food at a stable temperature. This allows the serving of food to be delayed. The "Keep warm" function is available between "0" and "1" heat settings and is shown on a cooking zone indicator as "L".

To activate the keep warm function

- Switch the hob on if necessary. Then simply touch the desired zone's selector (9) and set the power level using the "+" or "-" selectors to "L" (use the "+" selector to set the power level to 1 and then use the "-" selector once).
- The keep warm function's duration is limited to keep food as safe as possible. This duration is detailed on page 11.

To deactivate the keep warm function

- Touch the desired zone's selector (9) and either set the power level using the "+" or "-" selectors to "0" or, alternatively, touch and hold the cooking zone selector for 3 seconds. The cooking zone indicator will display a "0" to confirm that the zone is now inactive but will display an "h" or "H" if the zone is still hot to the touch.

Safety Key Lock

To prevent accidental use, the hob has a safety key lock which switches controls off temporarily or completely. The safety key lock can be deactivated when the hob is turned on or off but not when power has been switched off at, or the appliance disconnected from, the mains.

Please note: Disconnecting the appliance from the mains will deactivate the safety key lock.

To activate the safety key lock

To switch on the lock, turn on the hob and touch the safety key lock sensor (11) for approximately 5 seconds. The safety key lock indicator light (13) should illuminate.

To deactivate the safety key lock

To switch off the lock, touch the safety key lock sensor (11) for approximately 5 seconds. The safety key lock indicator light (13) should extinguish.

Residual Heat Indicator

The hob is equipped with residual heat indicators to warn when any of the zones are still hot to the touch after use. An “**h**” will show in a zone’s indicator if the relevant zone is between 45°C and 60°C. An “**H**” will show if the relevant zone is 60°C or above. You should avoid touching any zone whilst the hob is in use or whilst either residual heat indicator is displayed.

In the event of a power cut or failure, the residual heat indicators will illuminate after the power supply is restored. When there is no power supply to the hob however the residual heat indicators will not work, yet the hob zone(s) may still be hot, so extra care must be taken.

Efficient use of your hob

The hob is equipped with zones designed to accommodate most shapes and sizes of pan. For best results, only use pans with flat bottoms and choose an appropriate zone depending on the size of the pan. The most efficient use of the hob is shown below, where the pan and zone are correctly chosen.

Use pan lids where possible to minimize the energy usage of your appliance.

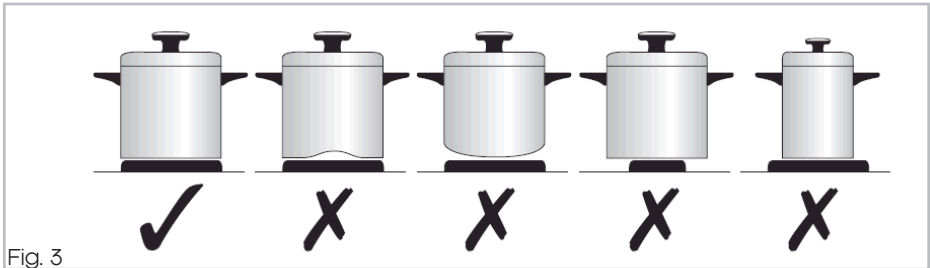

Fig. 3

Zone Size	Minimum Pan Size (mm)	Maximum Pan Size (mm)
160-180mm	90	160-180
210-220mm	140	210-220

It is very important that the pans used on the hob are made of a suitable material and have the correct type of base. The base of the pan and the hob top must be clean before use to prevent any scratches on the hob top.

Please note: Extra care should be taken if cast iron pans are used as these have coarse bases which may damage the hob top.

Care and Maintenance

Always disconnect the appliance from the power supply before undertaking any cleaning or maintenance.

Important:

- Steam cleaners must not be used when cleaning this appliance.
- You should use a non-abrasive cleaner to clean the hob top. Any abrasive cleaner (including Cif) will scratch the surface and could erase the control panel markings.
- Sugar and starch can cause permanent damage to the surface of the hob. Wipe away any spillages immediately but be careful given that the hob top will be hot during and after usage.
- Avoid letting pans boil over where possible to ensure that the need for cleaning is minimal.
- Always use a soft sponge or cloth where possible. Utensils such as scouring sponges and some brushes could cause scratches to the hob top.

A cleaning guide is available on page 18.

Troubleshooting

Problem	Possible Causes	Possible Remedy
The appliance does not work and no indicators are lit.	The appliance has no power	Check the fuse and replace if blown.
Sensor fields do not respond when touched.	<p>Appliance is not turned on</p> <p>A sensor field has been touched too briefly (less than a second)</p> <p>Multiple sensors have been touched/covered at the same time</p> <p>The safety key lock is engaged</p>	<p>Turn on the appliance</p> <p>Touch the sensor field again and for longer</p> <p>Only touch one sensor field at a time unless instructed otherwise</p> <p>Disengage the safety key lock as per page 15</p>
The appliance does not respond and emits an extended beep	Improper use (wrong sensor fields touched or touched too briefly)	Switch the appliance off via the on/off sensor and at the mains and then switch the power and appliance on again
The appliance switches itself off	<p>No heat level has been set within 10 seconds of activating the appliance</p> <p>Sensor fields covered or dirty</p>	<p>Switch on the appliance and set zone and heat setting without delay</p> <p>Uncover or clean the sensor fields</p>
A cooking zone switches itself off and a residual heat indicator is shown.	<p>Operating time limiter has activated.</p> <p>Sensor fields covered or dirty</p> <p>Electronic components have overheated</p>	<p>Nothing (see pages 10-11)</p> <p>Uncover or clean the sensor fields</p> <p>Nothing. Allow appliance to cool.</p>

Problem	Possible Causes	Possible Remedy
Residual heat indicator has extinguished despite zone(s) still being hot.	The appliance has no power	Check the fuse and replace if blown.
Hob top is broken, cracked and/or chipped.	Stop using the appliance immediately and switch the appliance off at the mains. Contact CDA Customer Care to arrange a repair.	
The appliance makes a buzzing noise.	Buzzing noises are normal whilst the hob is in use (inductor modules functioning) and after the hob has been used (cooling fan in operation).	
The appliance makes noises similar to whistles, hisses and pops.	These noises are normal. If several cooking zones are used at once then the hob can make hissing or whistling noises due to the frequencies used to power the inductor modules. Popping noises can often be heard when pans are being heated.	
Cooking zone or multiple zones do not work. One or more zones display a “E” symbol	The internal electronics may be faulty and in need of a reset. The selected pan is not suitable for use with this hob.	Reset the appliance by disconnecting it from the mains for a few minutes before reconnecting it. See page 6 for more information on selecting a correct pan.

Should any error code show on the zone displays, or the above steps not resolve an issue, please contact CDA Customer Care for assistance. Contact details are on page 18.

IMPORTANT - PLEASE NOTE: In the event of any breakage, crack or cracking – even minimal – of the vitroc ceramic glass, immediately disconnect your appliance to prevent a risk of electric shock and contact CDA Customer Care.

Fitting the hob

Unpacking the hob:

Take care not to lose, drop or mishandle any parts.

Fitting position of the hob:

This appliance must be installed a minimum of 55mm away from any adjacent vertical surfaces, e.g. a tall cupboard end panel. This may be reduced to 50mm if the adjacent surface is resistant to fire (tiles or steel for example). These dimensions are shown in Fig.8 on page 24.

Ventilation requirements:

This appliance must be installed to allow air to flow freely to the air intake and from the air outlet. An air gap of 10mm is recommended immediately below the hob. Failure to allow sufficient ventilation could cause problems with operation or damage to the hob and constitutes incorrect installation, which is not covered by the product's warranty (Figs. 4 and 5).

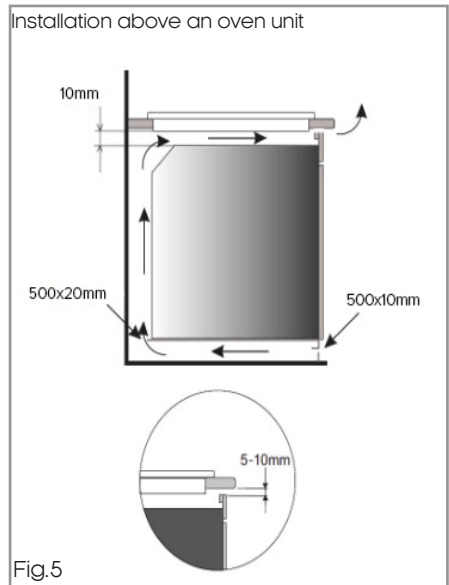
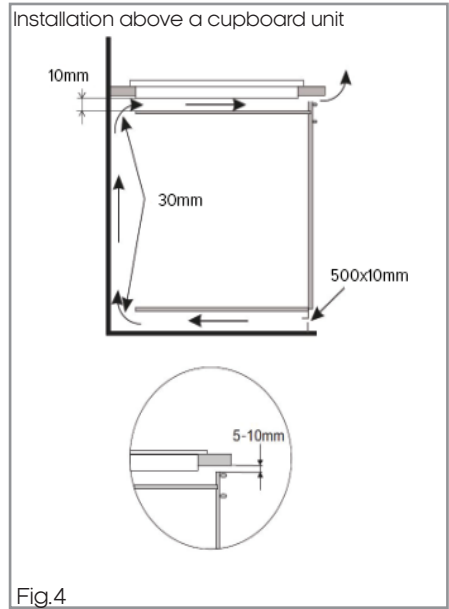

If fitting a cooker hood above the hob:

If a cooker hood is to be installed above the hob, the height of the hood above the hob must be at least 600mm (650mm is recommended) (Fig.6). If the instructions supplied with the hood dictate that the hood must be installed at a height greater than 600mm, then that height is the minimum required.

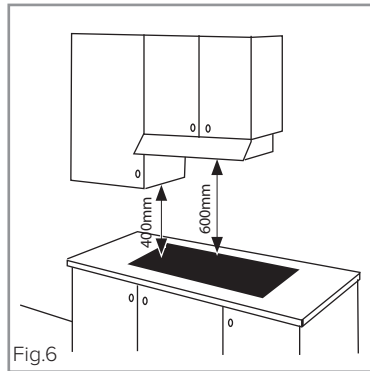

Wall furniture requirements:

The minimum height of any cabinet immediately above the hob is 750mm minimum. The minimum height of any adjacent units (including light pelmets) is 400mm, unless they are manufactured from a material resistant to fire (steel, for example).

Important notes:

- Do not position this appliance above a refrigeration unit. The heat generated may cause the refrigeration unit to fail.
- This appliance is designed to be installed into cabinet units capable of withstanding temperatures of 65°C or greater above ambient temperature.

Important notes:

- Never place perishable foods, cleaning products or flammable items in the cupboard below the appliance.
- If an oven is to be installed below the hob, the thermal safety system on the hob may not allow the hob to be used at the same time as a pyrolytic programme on the oven.
- **Ensure that the top rail is removed prior to installation, and that no unit cross member is blocking the air outlets.**
- If the hob is to be located above a working drawer, we recommend that the drawer is not used for storing soft items, for example dusters or towels; this is to minimize the risk of the cooling system air intakes being obstructed.

How to install the hob

Overall dimensions of the hob:

Width: 576 mm Depth: 518 mm

Worktop cut-out dimensions:

Width: 560 mm Depth: 495 mm

1. Make the required hole in the worktop. Before doing this, you must check the instructions supplied with any cooker hood to ensure that you will have the required clearance. The cut-out (Fig.8) shows a 50mm gap from the worktop edge to the cut-out edge. The distance from the hob, when fitted, to the back wall is to be 50mm.

If a splashback/worktop upstand is to be fitted, take this into account when cutting the hole.

2. Make sure that the worktop is clean and dust free and insert the hob into the cut-out opening. Press the hob firmly into place so that the seal connects with the worktop (Fig. 7).

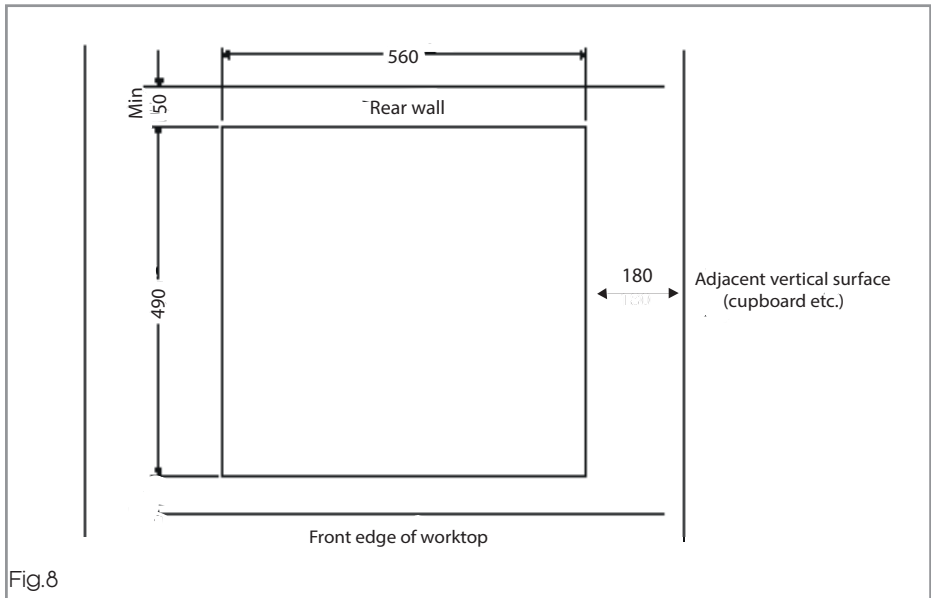
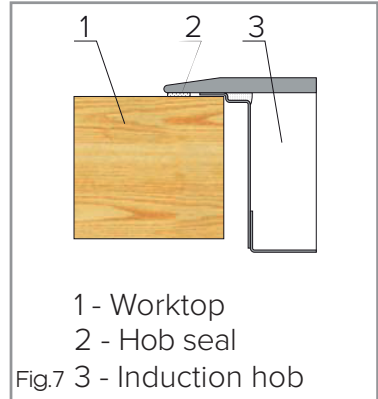

Fig.8

Mains Electricity Connection

Warning! This appliance must be earthed.

We recommend that the appliance is connected by a qualified electrician, who is a member of the N.I.C.E.I.C. and who will comply with the I.E.T. and local regulations.

This appliance is intended to be connected to fixed wiring and is not suitable for connection to a 13A plug or 13A supply.

This appliance is intended to be connected to fixed wiring by a double pole switch, having a contact separation of at least 3mm in all poles. The switch must be positioned no further than 2m from the appliance.

Please note:

- The mains cable must only be replaced by a qualified electrician or service engineer and must be of equivalent or better rating (i.e. 4mm², HO5VV-F).

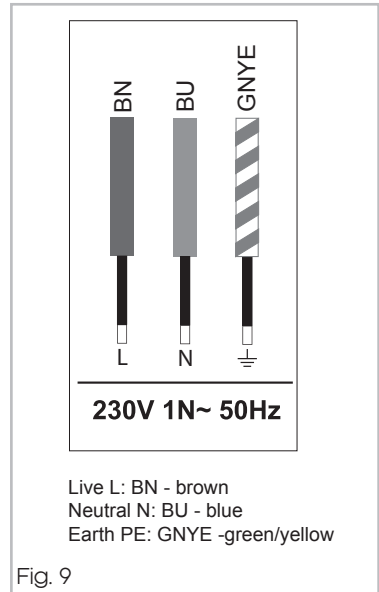

- This appliance is intended to be connected to the mains supply with a cable of cross sectional area 4mm².
- The current rating of the fuse or circuit breaker protecting this appliance should be marked on the socket outlet.
- Assembly and electrical connection should be carried out by specialised personnel.
- When installing this product we recommend you seek the help of another individual.
- **Should the mains cable be damaged or need to be replaced, it should only be done so by a qualified electrician or engineer. The connections to the hob are shown below;**

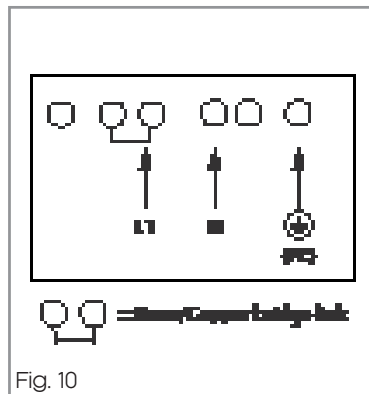

- Ensure that the brass links are securely fitted. Failure to do so may prevent the hob from operating correctly.

Appliance electrical rating: 7400W

Energy Efficiency Information

Attribute	Symbol	Value	Units
Matrix model		MHN101FR	
Type of hob		Built in	
Number of cooking zones and/or areas		4	
Heating technology (induction cooking zones and cooking areas, radiant cooking zones, solid plates)		Induction cooking zones	
For circular cooking zones or area: diameter of useful surface area per electric heated cooking zone, rounded to the nearest 5mm	∅	FL:21.0/ FR:16.0/ RL:16.0/ RR:21.0	cm
For non-circular cooking zones or areas: length and width of useful surface area per electric heated cooking zone or area, rounded to the nearest 5mm	L W	NA	cm
Energy consumption per cooking zone or area calculated per kg	EC <small>Electric cooking</small>	FL:188.9/ FR:188.9/ RL:188.9/ RR:188.9	Wh/kg
Energy consumption for the hob calculated per kg	EC <small>Electric hob</small>	188.9	Wh/kg

E & O E. All instructions, dimensions and illustrations are provided for guidance only. CDA reserve the right to change specifications without prior notice.



Serviced by



Built for your life

For our Customer Care Department, or for Service,
please contact us on: