



Manual for installation,
use and maintenance

MEH & MEP

Chimney Extractors



Important

The CDA Group Ltd cannot be held responsible for injuries or losses caused by incorrect use or installation of this product. Please note that CDA reserve the right to invalidate the guarantee supplied with this product following incorrect installation or misuse of the appliance or use in a commercial environment.

This appliance is not designed to be used by people (including children) with reduced physical, sensorial or mental capacity, or who lack experience or knowledge about it, unless they have had supervision or instructions on how to use the appliance by someone who is responsible for their safety.

Under no circumstances should any external covers be removed for servicing or maintenance except by suitably qualified personnel.

Appliance information:

Please enter the details on the appliance rating plate below for reference, to assist CDA Customer Care in the event of a fault with your appliance and to register your appliance for guarantee purposes.

Appliance Model	
Serial Number	

Declarations of Conformity:

This appliance has been manufactured to comply with all EU & UK statutory requirements and complies with all applicable legislation and the following European Directives:

- The Low Voltage Directive 2014/35/EU
- Electromagnetic Compatibility Directive 2014/30/EU

The product has been marked with the UKCA and CE symbols.



Parts intended to come into contact with food conform to 1935/2004/EC.

IMPORTANT INFORMATION FOR CORRECT DISPOSAL OF THE PRODUCT IN ACCORDANCE WITH EU DIRECTIVE 2012/19/EU.

At the end of its working life, the product must be taken to a special local authority waste collection centre or to a dealer providing appliance recycling services.

Disposing of a household appliance separately avoids possible negative consequences for the environment and health. It also enables the constituent materials to be recovered, saving both energy and resources. As a reminder of the need to dispose of household appliances separately, the product is marked with a crossed-out wheeled dustbin. 

Please note:

- Under no circumstances should the extractor be connected to any gas ventilation system, flue system or hot air ducting system.
- Do not vent the extractor into an attic or loft space.
- Only house the extractor in rooms with adequate ventilation. Remember that the extractor is powerful and whatever air is extracted needs to be replaced.
- Do not tile the extractor in. It should be removable for service or maintenance.
- Do not use silicone sealant to secure the hood to the wall.
- You must be able to isolate the extractor from the mains electrical supply after installation.
- Steam cleaners must not be used when cleaning this appliance.

- The performance of your extractor will vary depending on a number of factors. These include: type of extraction, length of ducting, room volume, ventilation available and cleanliness of the filters.

Using your extractor

For best performance, you should switch on the extractor 15 minutes before starting to cook and leave it to run for approximately 15 minutes after the end of cooking.

Control Panel

A = Power off button B = Speed level buttons C = Light button

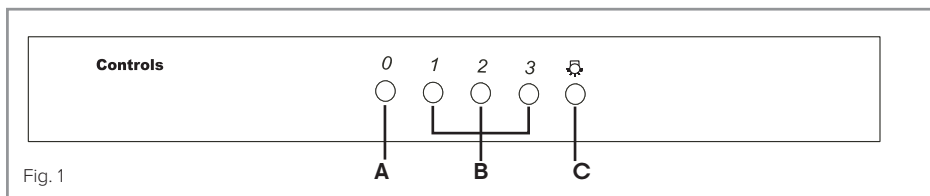

To switch the extractor light on or off

- Press button C.

To switch on the extractor or change the motor speed at any time when the extractor is running

- Press the relevant speed button (B) for the first, second or third speed as required.

To switch the extractor off

- Press button A.

Care and Maintenance

IMPORTANT : DO NOT PERFORM MAINTENANCE OR CLEANING OF THE EXTRACTOR WITHOUT FIRST SWITCHING OFF THE ELECTRICITY SUPPLY.

Cleaning

You should use a nonabrasive cleaner. Any abrasive cleaner (including Cif) will scratch the surface and could erase the control panel markings.

You can clean your extractor effectively by simply using a dilute solution of water and mild detergent and drying to a shine with a clean cloth.

Cleaning the grease filter

The grease filter should be kept clean to minimise the risk of fire.

At least once a month you should remove and clean the grease filter with hot soapy water. You can also wash the grease filter in a dishwasher, ensuring that you place it in an upright position to prevent damage from other items in the dishwasher. After rinsing and drying, replace the filter.

To remove the grease filter, push in the button on the handle and then pull down on the filter at the front. When you have released it at the front, then you can pull out the filter. To replace the grease filter, repeat the steps in reverse.

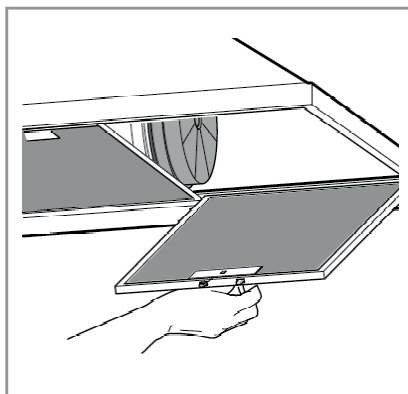

Please note:

Cleaning the grease filter in the dishwasher may lead to discolouration. This is normal and does not constitute a fault with the appliance.

Changing the charcoal filter (re-circulating only)

To ensure best performance of your extractor, you should replace the charcoal filter every four to six months, depending on use.

To attach a new charcoal filter, first remove the grease filters as described above.

Insert the charcoal filter into the guide on the side of the motor, then slide the filter in until it locks into place. Repeat with the second filter on the opposite side. Finally replace the grease filters.

Changing the light bulbs

DO NOT CHANGE THE LIGHT BULB IMMEDIATELY AFTER USE AS THE BULB WILL BE HOT. ALLOW IT TO COOL BEFORE REMOVING IT.

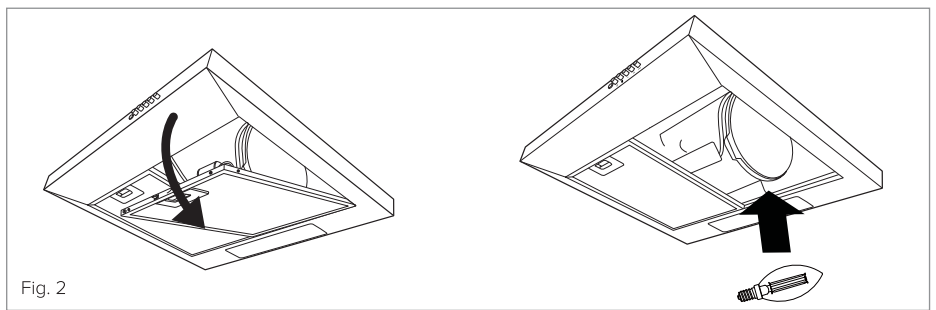
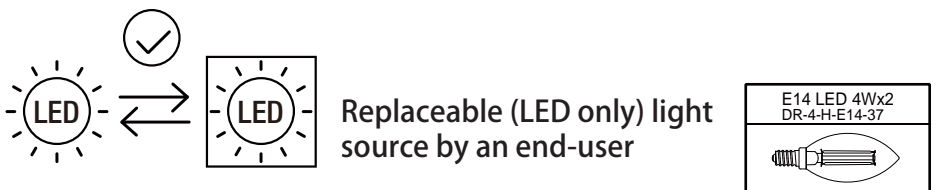

Remove the cover panel as described above, unscrew the light bulb and replace the light with the correct type of light bulb (4W max LED SES). Finally, replace the cover panel.

Do not touch bulbs or adjacent areas during or straight after prolonged use of the lights.

The light is designed for use during cooking and not for general room illumination. Extended use of the light can reduce the life span of the bulb.

Bulb replacement is not covered by the guarantee.

Only use bulbs recommended for your extractor. Do not fit bulbs of a higher power rating.

Bulbs of a lower power rating may be adequate for use, generally last longer and use less energy.

Electrical Information

Mains electrical voltage: 230 – 240Vac, 50Hz

Total rated power consumption:

128W

Troubleshooting

If your extractor is not working:

1. Check that the mains supply has not been switched off.
2. Check that the fuse in the spur has not blown.

Mains Electricity Connection

THIS APPLIANCE MUST BE CONNECTED TO THE MAINS SUPPLY BY A COMPETENT PERSON, USING FIXED WIRING VIA A DOUBLE POLE SWITCHED FUSE SPUR OUTLET AND PROTECTED BY A 3A FUSE.

Warning! This appliance must be earthed

We recommend that the appliance is connected by a qualified electrician, who is a member of the N.I.C.E.I.C. and who will comply with the I.E.T. and local regulations.

The wires in the mains lead of this appliance are coloured in accordance with the following code:

Green & Yellow = Earth, Blue = Neutral, Brown = Live.

As the colours of the wires in the mains lead for the appliance may not correspond

to the coloured markings identifying the terminals connecting to the fuse spur,

proceed as follows:

- The wire which is coloured green and yellow must be connected to the terminal marked E (Earth) or coloured green.
- The wire which is coloured blue must be connected to the terminal marked N (Neutral) or coloured black.
- The wire which is coloured brown must be connected to the terminal marked L (Live), or coloured red.

Note: Use a 3A Fuse

Assembly and electrical connection should be carried out by specialised personnel.

When installing this product we recommend you seek the help of another individual.

Do not mount the isolation switch behind the chimney section. It is a requirement that you must be able to isolate the extractor from the mains electrical supply after installation.

This appliance is intended to be connected to the mains electrical supply by means of an isolation switch and fused spur and is intended to be protected by a 3A fuse. The use of a 13A fuse can cause damage to the internal wiring in the event of a fault, and may also invalidate the warranty.

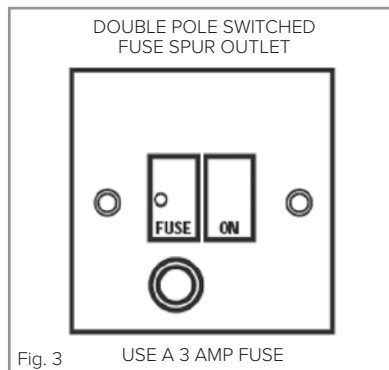

Fig. 3

USE A 3 AMP FUSE

Mounting your extractor

When the extractor is to be installed above an electric hob, the minimum distance between the hob and extractor must exceed 600mm (650mm is recommended).

When the extractor is to be installed above a gas hob, the minimum distance between the hob and extractor must exceed 700mm (750mm is recommended).

* The actual height of C depends on the height of the ceiling and the position of the hob.

If the instructions provided with your gas hob state that the required distance between the hob and extractor must be greater than 700mm, then that is the distance that should be observed; this is a legal requirement and may lead to your hob being disconnected from the gas supply and the installation being reported under RIDDOR (The height should be measured from the top of the burners).

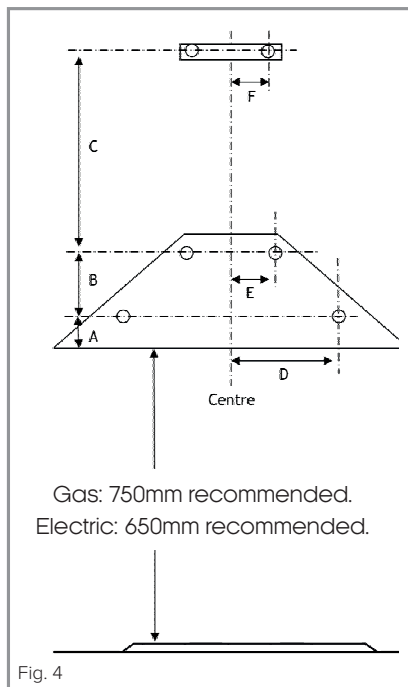

	MEH601	MEH901	MEP601/901
A	60.5	60.5	53.5
B	120.5	120.5	169.5
C*	725 max	725 max	550
D	175	200	105
E	75	75	75
F	80	80	73

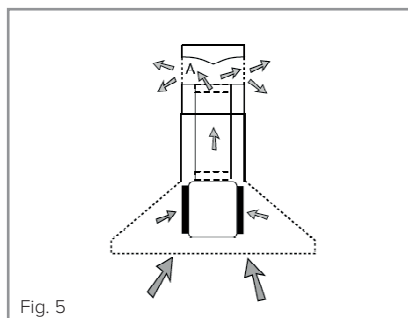

IN THE ABSENCE OF ANY INSTRUCTIONS SUPPLIED WITH THE GAS HOB, THE MINIMUM DISTANCE BETWEEN THE HOB AND EXTRACTOR MUST BE AT LEAST 760mm.

The width of any hob must not be greater than the width of the extractor installed above it (Fig. 4).

Ducting and Ventilation

For best performance and lowest noise output, we recommend the use of 125mm ducting. You can also use 100mm ducting but this will reduce performance.

Wherever possible utilise rigid circular pipe which has a smooth interior, rather than the expanding concertina type ducting. The lengths of the ducting without performance being affected are as follows:

- 4 metres with 1 x 90° bend.
- 3 metres with 2 x 90° bends.
- 2 metres with 3 x 90° bends.

Longer ducting can be used but the performance of the extractor will likely be reduced.

Please note: Ducting components and ducting kits are optional accessories and have to be ordered, they are not automatically supplied with the hood. Use of ducting less than 125mm in diameter will affect performance and increase the noise produced by the extractor.

Installation steps

Tools required

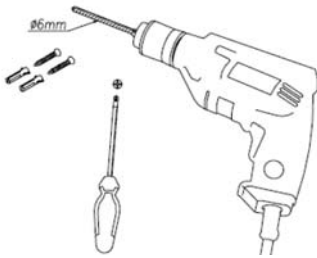

Fig. 6

Mark wall as required (see table 2)

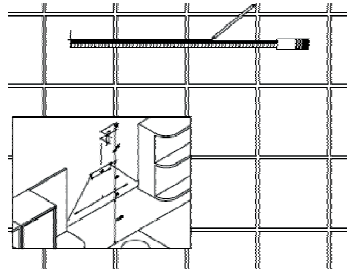

Fig. 7

Drill holes

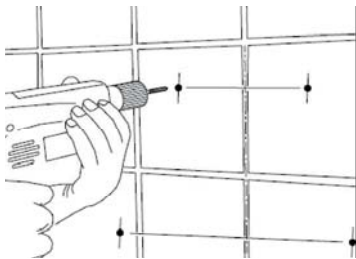

Fig. 8

Fit wall fixings and top screws - Ensure that any fixings you use are appropriate for the wall type.

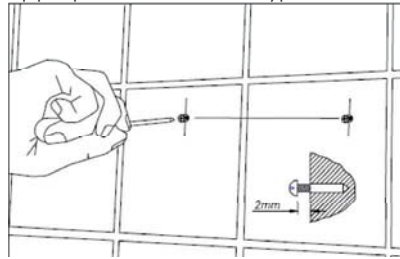

Fig. 9

Secure hood (tighten all screws)

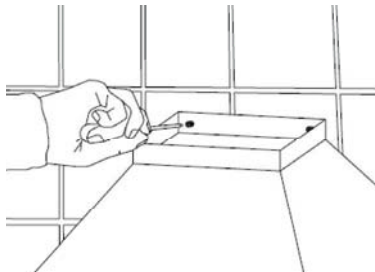

Fig. 10

Fit ducting adaptor

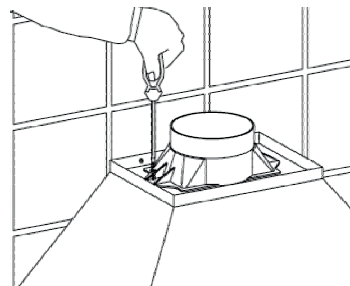

Fig. 11

IMPORTANT SAFETY WARNING: ONLY USE THE SCREWS PROVIDED WITH THE EXTRACTOR TO MOUNT THE DUCTING ADAPTOR. THE USE OF LONGER SCREWS MAY CAUSE DAMAGE TO THE INTERNAL WIRING WHICH WILL NOT BE COVERED BY THE WARRANTY.

Mount chimney brackets

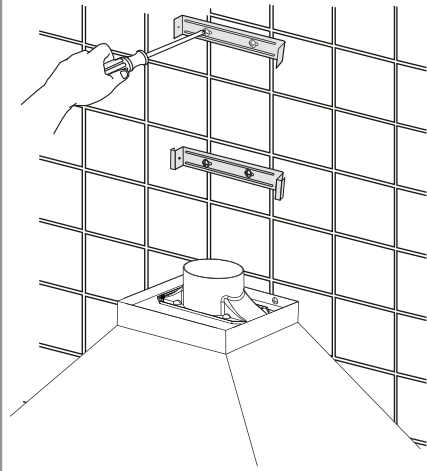

Fig. 12

Fix ducting (seal joint)

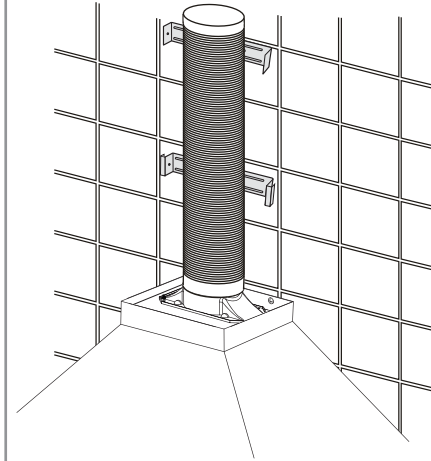

Fig. 13

Mount the chimney

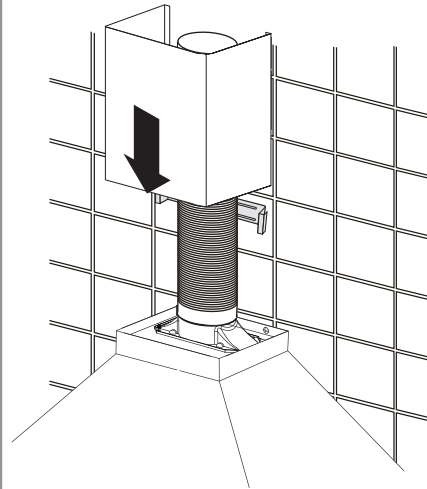

Fig. 14

Adjust and secure the chimney

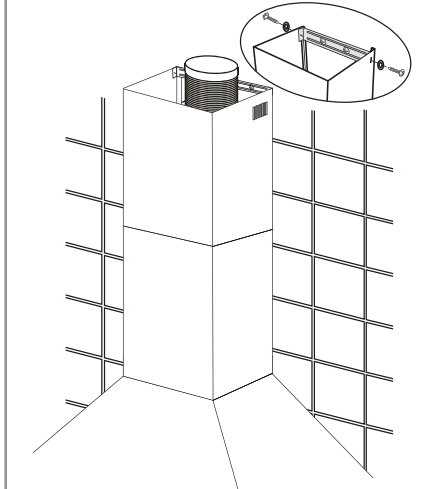

Fig. 15

The metal casing of this appliance has been coated with a preservative to protect it during transport and storage. This should be removed during installation by using a non-abrasive stainless steel cleaner. Always follow the instructions given with the cleaner being used.

NOTES:

Energy Efficiency Information					
Attribute	Symbol	Value			Units
Model Identification		MEH601	MEH901	MEP601/901	
Annual Energy Consumption	AEC_{Hood}	59	58.8	64.2	kWh
Time increase factor	f	1.6	1.6	1.7	
Fluid Dynamic Efficiency	FDE_{Hood}	11.5	11.6	9.6	
Energy Efficiency Index	EEl_{Hood}	84.1	83.9	88.1	
Measured airflow at Best Efficiency Point	Q_{BEP}	220.9	190.3	181.8	m^3/h
Measured Pressure at Best Efficiency Point	P_{BEP}	172.0	200	184.0	Pa
Maximum airflow	Q_{MAX}	382.3	372.1	336.4	m^3/h
Measured electric power at Best Efficiency Point	W_{BEP}	91.8	91.6	96.6	W
Nominal lighting power	WL	8	8	8	W
Average illumination of the lighting system on the cooking surface	E_{Middle}	114	114	114	Lux
Measured power consumption in standby	P_S	NA	NA	NA	W
Measured power consumption off mode	P_O	0.0	0.0	0.0	W
Sound power level	L_{WA}	67.0	70.0	69.0	dBA
Grease Filter Efficiency	GFE_{Hood}	63.4 (E)	64.2 (E)	66.4 (D)	%
Lamp efficiency	LE_{Hood}	14.3(D)	14.3(D)	14.3(D)	%



Serviced by



Built for your life

For our Customer Care Department, or for Service,
please contact us on:

The CDA Group Ltd. Harby Road, Langar, Nottinghamshire, NG13 9HY
Tel: 01949 862012 **Fax:** 01949 862003 **Email:** customer.care@cda.eu