



Manual for installation,  
use and maintenance

---

**MFU201**

Undercounter fridge



## Important

The CDA Group Ltd cannot be held responsible for injuries or losses caused by incorrect use or installation of this product. Please note that CDA reserve the right to invalidate the guarantee supplied with this product following incorrect installation or misuse of the appliance or use in a commercial environment.

This appliance is not designed to be used by people (including children) with reduced physical, sensorial or mental capacity, or who lack experience or knowledge about it, unless they have had supervision or instructions on how to use the appliance by someone who is responsible for their safety.

Under no circumstances should any external covers be removed for servicing or maintenance except by suitably qualified personnel.

### **Appliance information:**

Please enter the details on the appliance rating plate below for reference, to assist CDA Customer Care in the event of a fault with your appliance and to register your appliance for guarantee purposes.

Appliance Model	
Serial Number	

### **EU Declarations of Conformity**

This appliance has been manufactured to the strictest standards and complies with all applicable legislation, including Electrical safety (LVD) 2014/35/EU and Electromagnetic interference (EMC) 2014/30/EU.

Parts intended to come into contact with food conform to 1935/2004/EC.

**IMPORTANT INFORMATION FOR CORRECT DISPOSAL OF THE PRODUCT IN ACCORDANCE WITH EU DIRECTIVE 2012/19/EU.**

At the end of its working life, the product must not be disposed of as urban waste. The refrigeration system contains insulating gases and refrigerants, which require specialised waste disposal. The valuable materials contained in this appliance can be recycle. It must be taken to a special local authority differentiated waste collection centre or to a dealer providing this service.

Before disposing of an old appliance, remove the door seals, latch or bolt lock to avoid the risk of child entrapment.

Disposing of a household appliance separately avoids possible negative consequences for the environment and health. It also enables the constituent materials to be recovered, saving both energy and resources. As a reminder of the need to dispose of household appliances separately, the product is marked with a crossed-out wheeled dustbin. 

## Important

Never store inflammable or explosive items and strong corrosive acids or alkalis in the appliance.

This is a household appliance, which is produced in accordance with the national standard. It is intended for food storage only, not for storage of blood, medicine and biological products.

To prevent risk of fire, keep the appliance away from petrol or any other inflammables.

To prevent risk of electromagnetic interference or other accidents, do not place a microwave oven on top of the refrigerator or use any electric appliance inside the refrigerator.

Do not allow children to play with or near the appliance.

The internal surfaces of the fridge compartment may be very cold when the appliance is running. Avoid touching, if possible, the surfaces especially when hands are wet.

Do not splash water onto the appliance. Keep it away from places of high humidity that may have adverse effect on the electric insulation performance.

This appliance is designed to be used in ambient temperatures between 10 and 32°C. Use outside of this range may cause the appliance to fail.

This refrigeration appliance is intended for use as a built-in appliance.

## Before first use

**You must allow the fridge to settle for at least twenty four hours prior to switching the power on.**

It is recommended that you clean the interior of the appliance prior to first use, using a solution of bicarbonate of soda and warm water and then thoroughly drying the interior.

The fridge may have an odour to it at first use. This will disappear as the appliance cools.

When first switching the appliance on it is advisable to set the fridge to setting 3 on the thermostat dial and leaving the fridge to settle for 24 hours before adjusting the temperature to the preferred setting.

### **Please note:**

The appliance will work continuously until it comes down to the correct temperature.

If the appliance is switched off, you should allow five minutes before switching it on again to prevent unnecessary damage to the compressor.

Never store inflammable or explosive items and strong corrosive acids or alkalis in the appliance.

This fridge cools your food by making the inside back of the cavity cold. It is normal for frost to build up on this surface; it then dissipates and drains through a small drain at the bottom, where it evaporates harmlessly. The presence of frosting at the back is not a malfunction of the fridge.

# Use

## **Fridge**

- Never put liquids in the refrigerator uncovered.
- Never put hot foods in the refrigerator. Warm food should be allowed to cool to room temperature before being put into the refrigerator.
- Nothing should rest against the rear wall of the refrigerator, as this will cause frost and possible condensation problems which will be difficult to remove.
- Make sure food is clean and any extra water is wiped away before putting into the fridge.
- Wrap or cover food before putting into the fridge. This will help prevent the loss of moisture, keep food fresh and avoid unpleasant odours.
- Sort foods prior to storing. Any foods to be used soon should be stored at the front of the shelf to prevent deterioration caused by the door being open for prolonged periods.
- Do not overfill the fridge. There should be sufficient space between the foods to allow the cool air to circulate.
- Thawing frozen foods in the fridge compartment will help to keep the temperature low and save energy.

## Storage and use

The fridge is for short term food storage. Although the temperature can be maintained between 0-10°C, extended periods of food storage is not recommended.

As the cold air circulates within the fridge, the temperature can vary between the different sections. As such, foods should be stored in different sections according to type.

1. Butter and eggs
2. Food in jars and bottles
3. Drinks, e.g. milk
4. Cooked food
5. Yoghurts and cheese
6. Fresh meat and fish
7. Fruit and vegetables

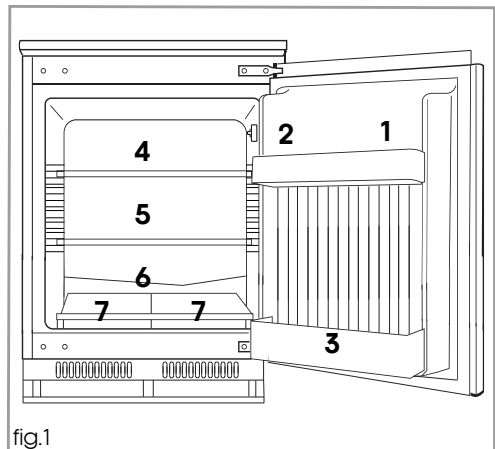

The fridge shelves can be moved according to the storage requirements within the fridge section. To move the shelf, lift up the front section and then pull it outwards. To replace, slide the shelf back into the slot, and lower the front section.

When storing root vegetables with leaves, such as carrots or turnips, their leaves should be removed. This prevents the leaves from absorbing nutrients from within the vegetables.

**Note:** If the appliance does not have a freezer compartment ( ❄️ ) it is not suitable for freezing foodstuffs.

# Controls



## **Thermostat dial**

The controls for this fridge are simple and consist of a single thermostat dial. To change the temperature, simply turn the dial left and right to cycle through the available settings. A centrally located embossed arrowhead indicates the setting. In the above figure, the setting is '0'. The settings available range from 0 to 6 with 0 being the 'Off' setting and '6' being the coldest.

After changing the temperature setting, the time taken to achieve the new temperature will depend on how big the change is from the previous setting.

## **Switching On and Off**

When the fridge is connected to a power supply it will automatically switch on unless the thermostat dial is set to '0'. To switch the appliance on, turn the dial to a setting between 1 and 6. To switch the appliance off, turn the dial to setting '0'. If you are turning the appliance off for a long time, then switch off the mains power supply also.



## Care and cleaning

**Always disconnect the appliance from the power supply before any cleaning or maintenance.**

The fridge should be cleaned using a solution of bicarbonate of soda and lukewarm water. Do not use abrasive products or detergents. After washing, rinse and dry thoroughly.

Clean the shelves and balconies separately by hand with a mild solution of washing up liquid and water. Do not put them in the dishwasher.

The water drain hole at the back of the fridge compartment and the evaporating tray should be cleaned periodically to prevent the defrosted water from collecting inside the fridge compartment. The cleaning rod can be used to clean the drain hole.

If the appliance is not to be used for prolonged periods of time, unplug and clean the appliance. The door should be left slightly ajar to prevent the formation of mildew and unpleasant odours.

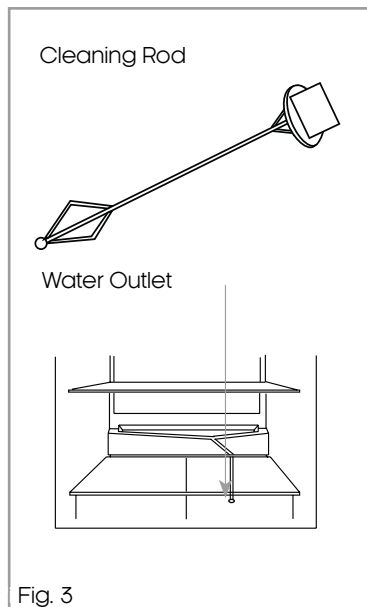

## Defrosting the fridge

The fridge is self-defrosting. Any water created will run out of the fridge through the channel at the back of the fridge.

It is important to keep the channel clear at all times using the cleaning tool supplied.

The defrosted water is collected in the evaporating tray at the back of the appliance and dissipated by evaporation.

If you notice a heavy build up of ice, refer to the troubleshooting section on ice on page 12.

## Troubleshooting

If you have any problems with your appliance, you should check the troubleshooting prior to calling CDA Customer Care to prevent unnecessary service calls and potential cost.

### **If the appliance is not working, check the following:**

- There is power to the appliance.
- The house fuses are intact and the fuse in the plug has not blown.
- The on/off switch is not set to off.
- The plug socket is functioning fine. To check this, plug another electrical appliance in to see if the socket is faulty.

### **If the appliance is working, but not very well, check the following:**

- The appliance is not overloaded.
- The thermostat is set to an appropriate temperature.
- The doors are closing properly.
- The cooling system at the rear of the appliance is clean and free of dust, and not touching the rear wall.
- There is enough ventilation at the side and rear walls.

### **If the appliance is noisy, check the following:**

- The appliance is level and stable.
- The side and rear walls are clear, and there is nothing resting on the appliance.
- **Note:** The cooling gas in the refrigerator may make a slight bubbling or gurgling noise, even when the compressor is not running.

**If there is water in the lower part of the refrigerator compartment, check the following:**

- The drain hole in the channel at the back of the compartment is clear.
- There are no items touching the rear wall of the appliance. If there are, adjust their position so that they no longer touch it.
- Check that there is some resistance when opening the door of the appliance. If it opens at the slightest touch it may mean that the door seal needs to be replaced.
- Check the door seal for any kinks, debris or damage. If you notice any, and are unable to resolve the issue yourself, contact CDA Customer Care so that the seal can be replaced.

**If ice has formed on the back wall of the fridge:**

- It is normal for some ice droplets to form on the back wall of the fridge. This does not constitute a fault with the appliance.
- Ensure that no items inside the fridge are in contact with the back wall.
- Check that there is some resistance when opening the door of the appliance. If it opens at the slightest touch it may mean that the door seal needs to be replaced.
- Check the door seal for any kinks, debris or damage. If you notice any, and are unable to resolve the issue yourself, contact CDA Customer Care so that the seal can be replaced.

## Installation and Ventilation

**This appliance must never be installed close to heat sources, e.g. heating elements, cookers or in damp places.**

- To ensure the appliance is level, you should use the height adjustable feet at the front of the appliance.
- The ventilation system at the bottom of the appliance must not be blocked.
- Fig. 4 shows the installation requirements for your appliance. All measurements are in millimetres. Failure to install the appliance correctly can lead to increased running costs, premature failure and may invalidate the warranty provided with the appliance.

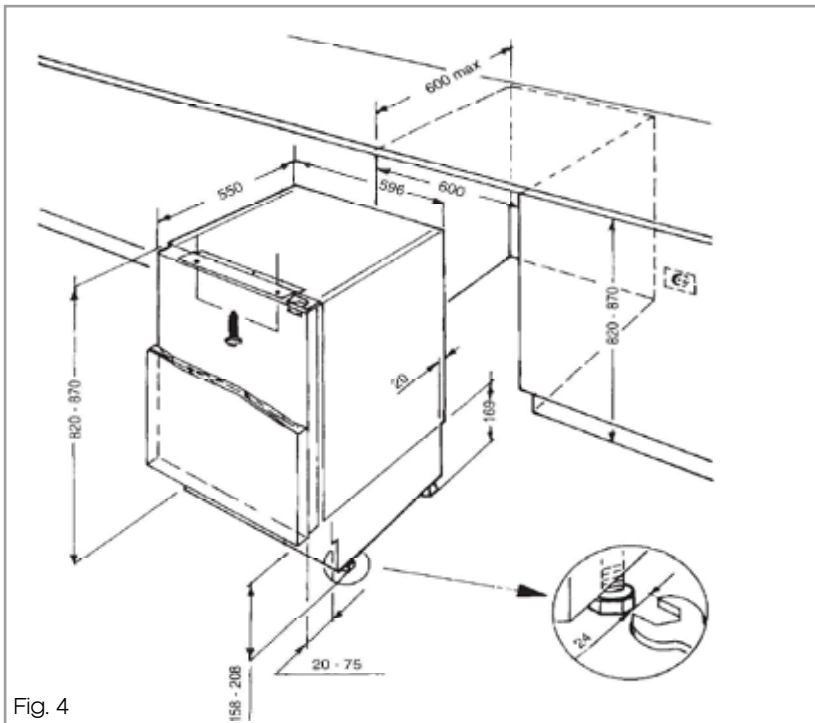

# Mounting the fascia doors

## Fig. 6 - Fitting the decor door bracket

Remove the white decorative cover (Fig. 5) by lifting it upwards.

Obtain the below measurements:

**Dimension B=** Measure from the underside surface of kitchen unit to the bottom of fixing bracket.

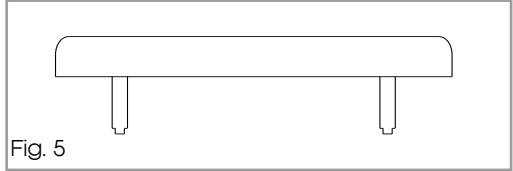

**Dimension C=** Measure from the underside surface of kitchen unit to the top of next unit door.

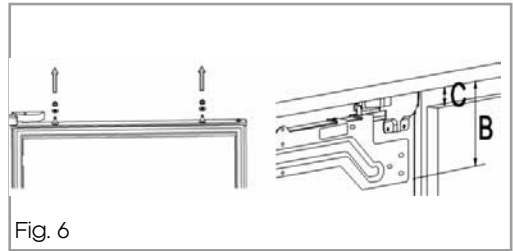

Unscrew and remove the nuts and washers from the top of the appliance door to remove the bracket.

## Fig. 7 - Fitting the decor door bracket

Subtract C from B and put the fixing bracket (2) in place using this measurement for vertical position and place to the centre for horizontal position. Secure the fixing bracket (2) using screws(1).

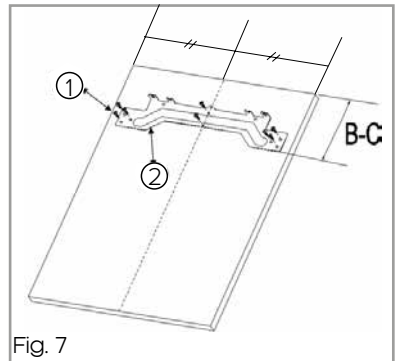

## Fig. 8 - Fitting the decor door

Place the decor door onto the appliance door by inserting adjustment bolts into the slots on the fixing bracket.

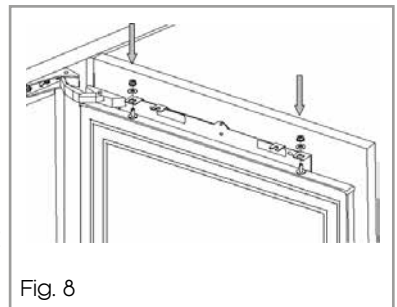

Locate the washers and screw the nuts onto the adjustment bolts.

### **Fig. 9 - Aligning the decor door**

Close the door and check the alignment with the other unit doors. Adjust the decor door by screwing or unscrewing the adjustment bolts for vertical adjustment and by the help of the slots on the fixing bracket for other directions. Lock the screws into place as shown in Fig. 9.

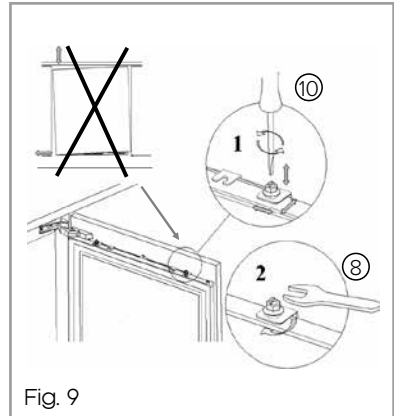

Fig. 9

### **Fitting the decor door base fixings**

With the appliance door open, locate the metal decor door base fixing brackets and screw the fixings to the decor door. You may need to remove and re-fit these brackets depending upon the decor door used.

### **Fitting the decorative cover**

Re-fit the decorative cover, that you removed in the first step, on to the decor door fixing bracket.

Check that the whole door assembly operates smoothly and that the door seal of the refrigerator is still creating a seal.

## Reversing the fridge door

We recommend you seek the help of another individual to support the doors whilst performing this operation.

1. Open the door.
2. Carefully prise off the white cover caps for the side that you wish to switch the hinges to.
3. Loosen the screws that hold the hinges to the fridge cabinet and remove the door.
4. Remove the screws that secure the hinge to the door.
5. Place the door somewhere safe where it will not cause or receive damage.
6. Relocate the hinges to their opposing corners as shown in Fig. 10.
7. Refit the door to the hinges.

**Do not turn the door upside down.**

8. Insert the cover caps (3) on the opposite side in the exposed holes.
9. Ensure that the door seal is correct, as per page 17.

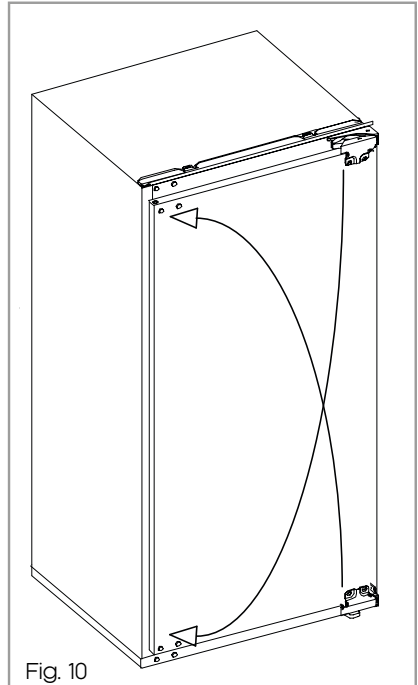

Fig. 10



**Ensuring the door seals correctly:**

It is normal for the seal to be compressed after the door has been reversed.

With the door closed, use a hair dryer to expand the seal and fill the gap between the door and the body of the appliance.

Take care not to use the hair dryer too close to the appliance, which could damage the seal. A distance of approximately 10cm should be adequate.

When completed, allow the seal and door to cool before touching them.

Once done, the seal will remain in position.

## Electrical Information

**Warning! This appliance must be earthed.**

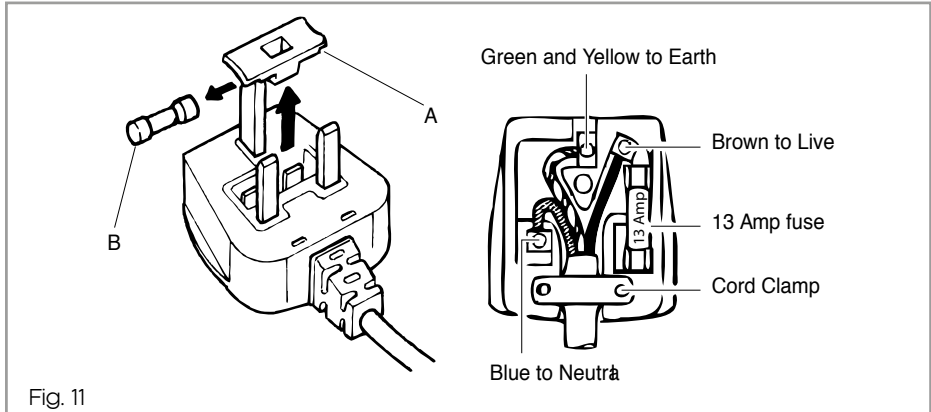

The mains lead of this appliance has been fitted with a BS 1363A 13Amp fused plug. To change a fuse in this type of plug, follow the steps below:

1. Remove the fuse cover and fuse.
2. Fit replacement 13A fuse, ASTA approved to BS 1362 type, into the fuse cover.
3. Replace fuse cover.

**Important: Do not use the appliance without the fuse cover in position.**

### How to connect an alternative plug

If the fitted plug is not suitable for your socket outlet, then it should be cut off and disposed of safely to avoid possible shock hazard. A suitable alternative plug of at least 13 Amp rating to BS 1363 should be used.

As the colours of the wires in the mains lead of this appliance may not

correspond with the coloured markings identifying the terminals in your plug, proceed as follows:-

- The wire which is coloured GREEN and YELLOW must be connected to the terminal which is marked with letter (E) or by the Earth symbol  $\perp$  or coloured GREEN and YELLOW.
- The wire which is coloured BLUE must be connected to the terminal which is marked with the letter (N) or coloured BLACK.
- The wire which is coloured BROWN must be connected to the terminal which is marked with the letter (L) or coloured RED.

If in doubt regarding the electrical connection of this appliance, consult a qualified electrician. Do not shorten the supply cable, the appliance may require removing for servicing.

**N.B. Ensure that the plug socket is situated in an easily accessible place after installation.**

## Changing the lamp bulb

Should the need to change or replace the bulb in your fridge arise, then the steps to do so are simple. **Ensure that the mains supply to the appliance has been switched off and that the bulb is not hot to the touch.** We recommend the use of gloves during these steps.

With a Phillips screwdriver, remove the screw that holds the bulb cover in place. To reach this screw it may be necessary to remove one or more shelves. Place said shelves in a place where they will not cause or receive damage. Take care not to lean any weight on the salad crisper covers as this may damage them.

Once the bulb cover has been removed, unscrew the bulb and remove it from the housing. Replace the defective bulb with a 15W Small Edison Screw (SES) bulb. Ensure that you wear gloves when handling the new bulb as this will help to preserve the lifespan of the bulb.

Replace the lamp cover, cover screw and shelves. Wait for at least 5 minutes before turning the fridge back on to avoid damaging the system.

## Climate range

The information about the climate range of the appliance is provided on the rating plate. It indicates at which ambient temperature (that is room temperature in which the appliance is working) is optimal for the operation of the appliance.

Climate class	Allowable ambient temperature
SN      Extended Temperate	This refrigeration appliance is intended for use at an ambient temperature ranging between 10°C and 32°C
N        Temperate	This refrigeration appliance is intended for use at an ambient temperature ranging between 16°C and 32°C
ST      Sub Tropical	This refrigeration appliance is intended for use at an ambient temperature ranging between 16°C and 38°C
T        Tropical	This refrigeration appliance is intended for use at an ambient temperature ranging between 16°C and 43°C

## Practical tips

Due to the natural circulation of the air in the appliance, there are different temperature zones in the refrigerator chamber. The coldest area is directly above the vegetable drawers. Use this area for all delicate and highly perishable food such as:

- Fish, meat, poultry
- Sausage products, ready meals
- Dishes or baked goods containing eggs or cream
- Fresh dough, cake mixtures
- Pre-packed vegetables and other fresh food with a label stating it should be stored at a temperature of approximately 4°C

The warmest area is in the top section of the door. Use this area for storing butter and cheese.

To achieve the most effective food preservation for the longest possible time and to avoid wasting any food, position the products as shown in Fig. 1. In addition this figure illustrates the layout of drawers, baskets and shelves, which allows the most efficient use of energy.

Optimal temperature and storage conditions will extend product shelf life and optimise electricity consumption. Optimal storage temperature range should be stated on the food packaging.

## Warranty and service

The manufacturer shall not be held liable for any damage caused by improper use of the product.

- Repairs carried out by unqualified persons may seriously endanger the appliance user
- Pursuant to Commission Regulation (EU) 2019/2019, The minimum availability period for spare parts necessary to repair the appliance is 7 or 10 years depending on the type and purpose of the spare part
- The list of spare parts and the ordering procedure are available on the websites of the manufacturer, importer or an authorised representative
- The minimum warranty period for the appliance offered by the manufacturer, importer or authorised representative is given in the warranty card
- The warranty shall be void if you make any independent adaptations or alterations, tamper with seals or other appliance safety devices or its parts or interfere with the appliance contrary to operating instructions

For more information about the product, please refer to the EU EPREL Product Database at <https://eprel.ec.europa.eu>.

Alternatively you can use your mobile device to scan the QR code on the energy label or enter the product model listed on the energy label in the EPREL search engine.



Serviced by



*Built for your life*

For our Customer Care Department, or for Service,  
please contact us on: