



Manual for installation,
use and maintenance

MFU251

Under-counter fridge
with icebox



Contents:

3	Important information
5	Important safety and usage instructions
6	Guidance before first use
7	General use of the fridge
8	General use of the freezer (icebox)
9	Storage and use
10	Controls
11	Care and cleaning
12	Defrosting the fridge
12	Defrosting the icebox
13	Troubleshooting
15	Installation and ventilation
16	Mounting the fascia doors
18	Reversing the fridge door
19	Reversing the icebox door
20	Electrical information
22	Changing the lamp bulb
23	Energy Efficiency Information

IMPORTANT: Please read the user instructions carefully before using the appliance for the first time and before installing it. Failure to install the fridge, or to have it installed, as per the user manual could invalidate the warranty. Any service calls relating to misuse or incorrect installation could incur a service charge.

Important

The CDA Group Ltd cannot be held responsible for injuries or losses caused by incorrect use or installation of this product. Please note that CDA reserve the right to invalidate the guarantee supplied with this product following incorrect installation or misuse of the appliance or use in a commercial environment.

This appliance is not designed to be used by people (including children) with reduced physical, sensorial or mental capacity, or who lack experience or knowledge about it, unless they have had supervision or instructions on how to use the appliance by someone who is responsible for their safety.

Under no circumstances should any external covers be removed for servicing or maintenance except by suitably qualified personnel.

Appliance information:

Please enter the details on the appliance rating plate below for reference, to assist CDA Customer Care in the event of a fault with your appliance and to register your appliance for guarantee purposes.

Appliance Model	
Serial Number	

EU Declarations of Conformity

This appliance has been manufactured to the strictest standards and complies with all applicable legislation, including Electrical safety (LVD) 2014/35/EU and Electromagnetic interference (EMC) 2014/30/EU.

Parts intended to come into contact with food conform to 1935/2004/EC.

IMPORTANT INFORMATION FOR CORRECT DISPOSAL OF THE PRODUCT IN ACCORDANCE WITH EU DIRECTIVE 2012/19/EU.

At the end of its working life, the product must not be disposed of as urban waste. The refrigeration system contains insulating gases and refrigerants, which require specialised waste disposal. The valuable materials contained in this appliance can be recycle. It must be taken to a special local authority differentiated waste collection centre or to a dealer providing this service.

Before disposing of an old appliance, remove the door seals, latch or bolt lock to avoid the risk of child entrapment.

Disposing of a household appliance separately avoids possible negative consequences for the environment and health. It also enables the constituent materials to be recovered, saving both energy and resources. As a reminder of the need to dispose of household appliances separately, the product is marked with a crossed-out wheeled dustbin. 

Important

Never store inflammable or explosive items and strong corrosive acids or alkalis in the appliance.

This is a household appliance, which is produced in accordance with the national standard. It is intended for food storage only, not for storage of blood, medicine and biological products.

To prevent risk of fire, keep the appliance away from petrol or any other inflammables.

To prevent risk of electromagnetic interference or other accidents, do not place a microwave oven on top of the refrigerator or use any electric appliance inside the refrigerator.

Do not allow children to play with or near the appliance.

The internal surfaces of the fridge compartment may be very cold when the appliance is running. Avoid touching, if possible, the surfaces especially when hands are wet.

Do not splash water onto the appliance. Keep it away from places of high humidity that may have adverse effect on the electric insulation performance.

This appliance is designed to be used in ambient temperatures between 10 and 32°C. Use outside of this range may cause the appliance to fail.

Before first use

You must allow the fridge to settle for at least twenty four hours prior to switching the power on.

It is recommended that you clean the interior of the appliance prior to first use, using a solution of bicarbonate of soda and warm water and then thoroughly drying the interior.

The fridge may have an odour to it at first use. This will disappear as the appliance cools.

When first switching the appliance on it is advisable to set the fridge to setting 3 on the thermostat dial and leaving the fridge to settle for 24 hours before adjusting the temperature to the preferred setting.

Please note:

The appliance will work continuously until it comes down to the correct temperature.

If the appliance is switched off, you should allow five minutes before switching it on again to prevent unnecessary damage to the compressor.

Never store inflammable or explosive items and strong corrosive acids or alkalis in the appliance.

This fridge cools your food by making the inside back of the cavity cold. It is normal for frost to build up on this surface; it then dissipates and drains through a small drain at the bottom, where it evaporates harmlessly. The presence of frosting at the back is not a malfunction of the fridge.

The presence of some frosting within the icebox of the appliance is not a malfunction of the icebox.

Use

Fridge

- Never put liquids in the refrigerator uncovered.
- Never put hot foods in the refrigerator. Warm food should be allowed to cool to room temperature before being put into the refrigerator.
- Nothing should rest against the rear wall of the refrigerator, as this will cause frost and possible condensation problems which will be difficult to remove.
- Make sure food is clean and any extra water is wiped away before putting into the fridge.
- Wrap or cover food before putting into the fridge. This will help prevent the loss of moisture, keep food fresh and avoid unpleasant odours.
- Sort foods prior to storing. Any foods to be used soon should be stored at the front of the shelf to prevent deterioration caused by the door being open for prolonged periods.
- Do not overfill the fridge. There should be sufficient space between the foods to allow the cool air to circulate.
- Thawing frozen foods in the fridge compartment will help to keep the temperature low and save energy.

Use

Freezer (icebox)

- The freezer compartment is designed to store only frozen food.
- Never put hot or warm foods in the freezer, allow them to cool fully before putting them into the freezer.
- Follow the instructions on the food packaging for storage of frozen food. If no information is provided, foods should not be stored for more than three months after the purchase date.
- Store food in small packages (ideally less than 0.5kg). This reduces the freezing time and improves the quality of the food after thawing.
- Wrap food before putting into the freezer. To stop the wrapping sticking together, ensure it is dry.
- Label the food before freezing with information including type of food and dates of storage and expiry.
- Once food is thawed, it must not be refrozen unless it has been completely cooked. Only defrost as much food as is required, to prevent wastage.
- Bottled or canned drinks should not be stored in the freezer compartment as they could explode.
- The maximum amount of fresh food that can be frozen within a 24 hour period is approximately 2 kg.
- Do not attempt to freeze more than the maximum amount.

Storage and use

The fridge is for short term food storage. Although the temperature can be maintained between 0-10°C, extended periods of food storage is not recommended.

As the cold air circulates within the fridge, the temperature can vary between the different sections. As such, foods should be stored in different sections according to type.

1. Butter and eggs
2. Food in jars
3. Drinks & bottles, e.g. milk
4. Frozen foods
5. Cooked food and dairy
6. Fresh meat and fish
7. Fruit and vegetables
(in crisper drawers)

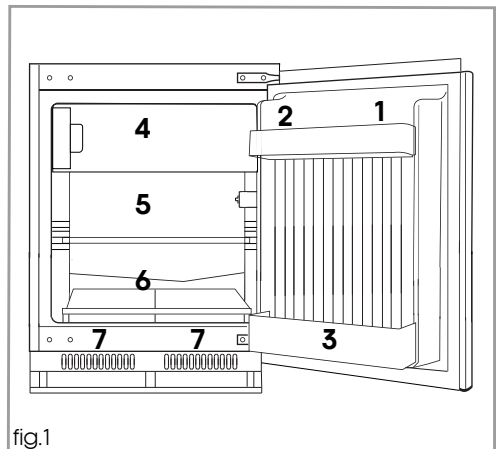

The fridge shelf can be moved according to the storage requirements within the fridge section. To move the shelf, lift up the front section and then pull it outwards. To replace, slide the shelf back into the slot, and lower the front section.

When storing root vegetables with leaves, such as carrots or turnips, their leaves should be removed. This prevents the leaves from absorbing nutrients from within the vegetables. The crisper cover shelf is split to allow easy access to the crispers.

Controls



Thermostat dial

The controls for this fridge are simple and consist of a single thermostat dial. To change the temperature, simply turn the dial left and right to cycle through the available settings. A centrally located embossed arrowhead indicates the setting. In the above figure, the setting is '0'. The settings available range from 0 to 6 with 0 being the 'Off' setting and '6' being the coldest.

After changing the temperature setting, the time taken to achieve the new temperature will depend on how big the change is from the previous setting and the fridge's contents.

Switching On and Off

When the fridge is connected to a power supply it will automatically switch on unless the thermostat dial is set to '0'. To switch the appliance on, turn the dial to a setting between 1 and 6. To switch the appliance off, turn the dial to setting '0'. If you are turning the appliance off for a long time, then switch off the mains power supply also.

Care and cleaning

Always disconnect the appliance from the power supply before any cleaning or maintenance.

The fridge should be cleaned using a solution of bicarbonate of soda and lukewarm water. Do not use abrasive products or detergents. After washing, rinse and dry thoroughly.

Clean the shelves and balconies separately by hand with a mild solution of washing up liquid and water. Do not put them in the dishwasher.

The water drain hole at the back of the fridge compartment and the evaporating tray should be cleaned periodically to prevent the defrosted water from collecting inside the fridge compartment. The cleaning rod can be used to clean the drain hole. Always ensure that the drainage channel, visible at the rear of the appliance, is kept clear of debris. If you notice that the drain hole/channel is iced over, use warm (**not boiling**) water to remove the ice blockage.

If the appliance is not to be used for prolonged periods of time, unplug and clean the appliance. The door should be left slightly ajar to prevent the formation of mildew and unpleasant odours.

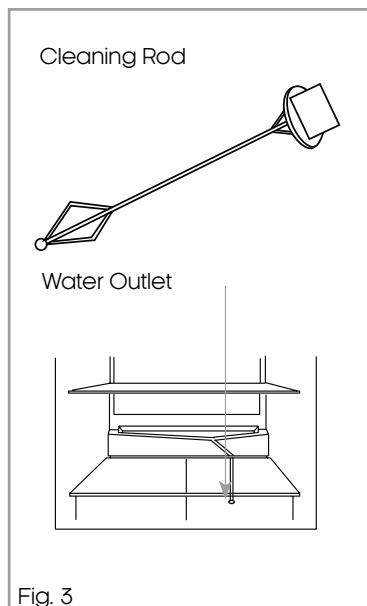

Defrosting the fridge

The fridge is self-defrosting. Any water created will run out of the fridge through the channel at the back of the fridge.

It is important to keep the channel clear at all times using the cleaning tool supplied.

The defrosted water is collected in the evaporating tray at the back of the appliance and dissipated by evaporation.

If you notice a heavy build up of ice, refer to the troubleshooting section on ice on page 14.

Defrosting the icebox

An excessive build-up of ice or frost in your icebox will lead to decreased efficiency and potentially increase your energy bills. We recommend defrosting the icebox at least once a year or whenever the ice build-up inside is thicker than $\frac{1}{4}$ of an inch.

The safest way to defrost your icebox is by switching the appliance off and leaving the doors open until all of the ice has melted away. Ensure you place old towels on the floor at the base of the appliance to catch any water that runs from the appliance. We advise against the use of newspapers to catch the water as the ink can run and ruin floors or units.

Removing chunks of the ice/frost as it is defrosting will speed up the process. Do not use any sharp objects or implements, hair driers or heat guns as these can cause irreversible damage.

Troubleshooting

If you have any problems with your appliance, you should check the troubleshooting prior to calling CDA Customer Care to prevent unnecessary service calls and potential cost. Contact details are on page 22 of this manual.

If the appliance is not working, check the following:

- There is power to the appliance.
- The house fuses are intact and the fuse in the plug has not blown.
- The thermostat dial is not set to '0'.
- The plug socket is functioning fine. To check this, plug another electrical appliance in to see if the socket is faulty.

If the appliance is working, but not very well, check the following:

- The appliance is not overloaded.
- The thermostat is set to an appropriate temperature.
- The doors are closing properly.
- The cooling system at the rear of the appliance is clean and free of dust, and not touching the rear wall.
- There is enough ventilation at the side and rear walls and the lower vents are neither blocked nor dirty.

If the appliance is noisy, check the following:

- The appliance is level and stable.
- The side and rear walls are clear, and there is nothing resting on the appliance.
- **Note:** The cooling gas in the refrigerator may make a slight bubbling or gurgling noise, even when the compressor is not running.

If there is water in the lower part of the refrigerator compartment, check the following:

- The drain hole in the channel at the back of the compartment is clear.
- There are no items touching the rear wall of the appliance. If there are, adjust their position so that they no longer touch it.
- Check that there is some resistance when opening the door of the appliance. If it opens at the slightest touch it may mean that the door seal needs to be replaced.
- Check the door seal for any kinks, debris or damage. If you notice any, and are unable to resolve the issue yourself, contact CDA Customer Care so that the seal can be replaced.

If ice has formed on the back wall of the fridge:

- It is normal for some ice droplets to form on the back wall of the fridge. This does not constitute a fault with the appliance.
- Ensure that no items inside the fridge are in contact with the back wall.
- Check that there is some resistance when opening the door of the appliance. If it opens at the slightest touch it may mean that the door seal needs to be replaced.
- Check the door seal for any kinks, debris or damage. If you notice any, and are unable to resolve the issue yourself, contact CDA Customer Care so that the seal can be replaced.

If excessive ice has formed in the icebox

- This may mean that warm air is entering the fridge/icebox. Carry out the above door seal checks for the fridge door and icebox door. If you have reversed the icebox door hinge side, ensure it is closing properly.

Installation and Ventilation

This appliance must never be installed close to heat sources, e.g. heating elements, cookers or in damp places.

- To ensure the appliance is level, you should use the height adjustable feet at the front and rear of the appliance. The feet offer approximately 50mm of adjustment height-wise.
- The ventilation system at the bottom of the appliance must not be blocked.
- Fig. 4 shows the installation requirements for your appliance. All measurements are in millimetres. Failure to install the appliance correctly can lead to increased running costs, premature failure and may invalidate the warranty provided with the appliance.

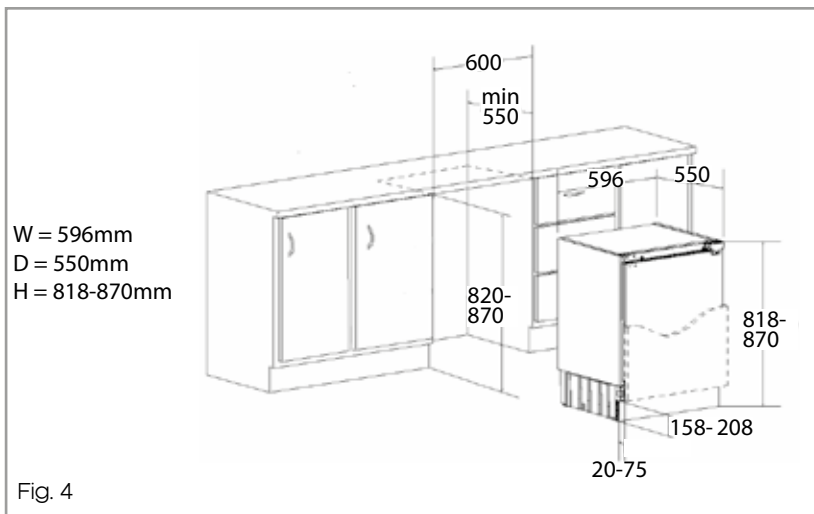

- The metal trim attached to the top of the appliance (**not** the decor door fixing bracket pictured in Fig. 7) has a number of holes in it. Use two or more of these holes to secure the appliance to the worktop.

Mounting the fascia doors

Fig. 6 - Fitting the decor door bracket

Remove the white decorative cover (Fig. 5) by lifting it upwards.

Obtain the below measurements:

Dimension B= Measure from the underside surface of kitchen unit to the bottom of fixing bracket.

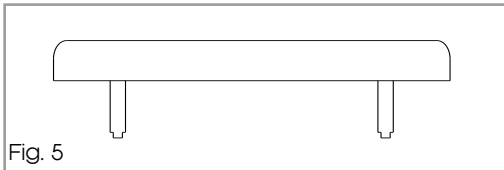

Dimension C= Measure from the underside surface of kitchen unit to the top of next unit door.

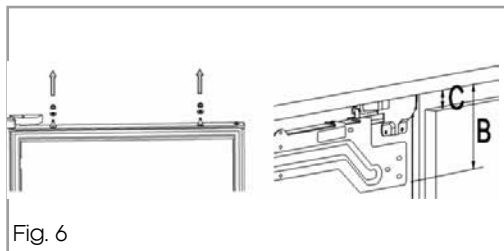

Unscrew and remove the nuts and washers from the top of the appliance door to remove the bracket.

Fig. 7 - Fitting the decor door bracket

Subtract C from B and put the fixing bracket (2) in place using this measurement for vertical position and place to the centre for horizontal position. Secure the fixing bracket (2) using screws(1).

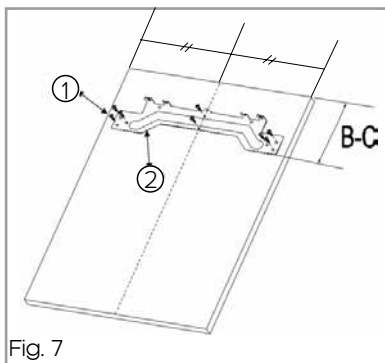
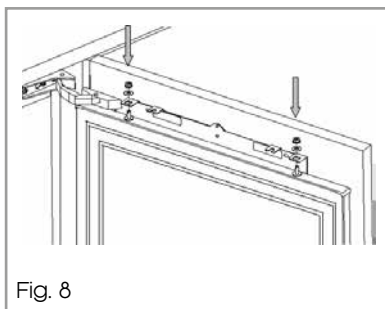

Fig. 8 - Fitting the decor door

Place the decor door onto the appliance door by inserting adjustment bolts into the slots on the fixing bracket.



Locate the washers and screw the nuts onto the adjustment bolts.

Fig. 9 - Aligning the decor door

Close the door and check the alignment with the other unit doors. Adjust the decor door by screwing or unscrewing the adjustment bolts for vertical adjustment and by the help of the slots on the fixing bracket for other directions. Lock the screws into place as shown in Fig. 9.

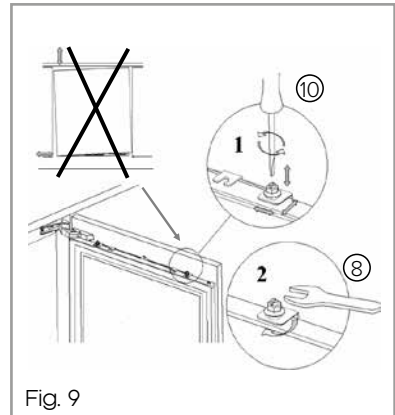

Fitting the decor door base fixings

With the appliance door open, locate the metal decor door base fixing brackets and screw the fixings to the decor door. You may need to remove and re-fit these brackets depending upon the decor door used.

Fitting the decorative cover

Re-fit the decorative cover, that you removed in the first step, on to the decor door fixing bracket.

Check that the whole door assembly operates smoothly and that the door seal of the refrigerator is still creating a seal (see pages 18-19).

Reversing the fridge door

We recommend you seek the help of another individual to support the doors whilst performing this operation.

1. Open the door.
2. Carefully prise off the white cover caps for the side that you wish to switch the hinges to.
3. Loosen the screws that hold the hinges to the fridge cabinet and remove the door.
4. Remove the screws that secure the hinge to the door.
5. Place the door somewhere safe where it will not cause or receive damage.
6. Relocate the hinges to their opposing corners as shown in Fig. 10.
7. Refit the door to the hinges.

Do not turn the door upside down.

8. Insert the cover caps (3) on the opposite side in the exposed holes.
9. Ensure that the door seal is correct, as per below and page 18.

Ensuring the door seals correctly:

It is normal for the seal to be compressed after the door has been reversed. With the door closed, use a hair dryer to expand the seal and fill the gap between the door and the body of the appliance.

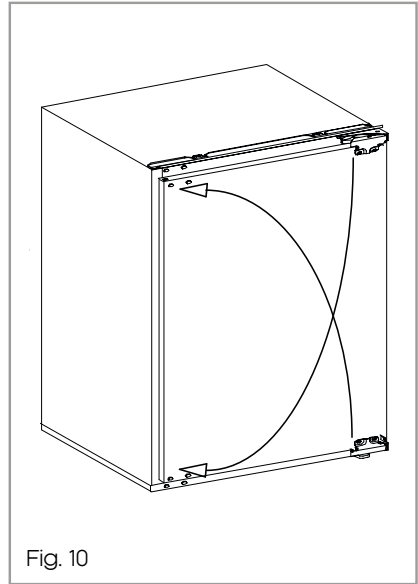

Fig. 10

Take care not to use the hair dryer too close to the appliance, which could damage the seal. A distance of approximately 10cm should be adequate. When completed, allow the seal and door to cool before touching them. Once done, the seal should remain in position.

Reversing the icebox door

Remove the lower hinge piece (circled in Fig. 11) by removing the two screws holding it in place. The door will begin to drop once this has been removed so

take care. Place the door somewhere safe and remove the lower hinge piece. Carefully take out the white cover caps from the



opposite side. Place these in the old hinge position holes.

Remove the door latch strike plate (Fig. 12) and mirror its position on the opposite side.

Re-fit the door in the new position, ensuring that the upper hinge pivot on the door goes into the recess in the top of the fridge. Latch the door over the strike plate and fit the lower hinge piece in its new position. Test that the icebox



door functions properly and make any necessary adjustments.

Electrical Information

Warning! This appliance must be earthed.

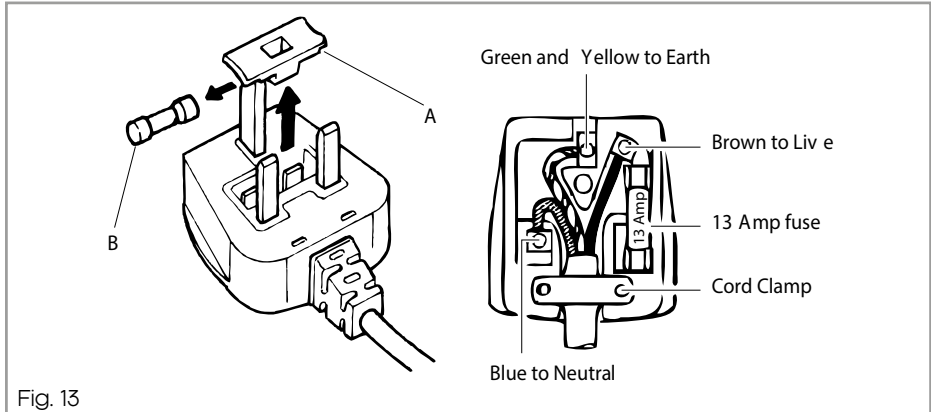

The mains lead of this appliance has been fitted with a BS 1363A 13Amp fused plug. To change a fuse in this type of plug, follow the steps below:

1. Remove the fuse cover and fuse.
2. Fit replacement 13A fuse, ASTA approved to BS 1362 type, into the fuse cover.
3. Replace fuse cover.

Important: Do not use the appliance without the fuse cover in position.

How to connect an alternative plug

If the fitted plug is not suitable for your socket outlet, then it should be cut off and disposed of safely to avoid possible shock hazard. A suitable alternative plug of at least 13 Amp rating to BS 1363 should be used.

As the colours of the wires in the mains lead of this appliance may not

correspond with the coloured markings identifying the terminals in your plug, proceed as follows:-

- The wire which is coloured GREEN and YELLOW must be connected to the terminal which is marked with letter (E) or by the Earth symbol \perp or coloured GREEN and YELLOW.
- The wire which is coloured BLUE must be connected to the terminal which is marked with the letter (N) or coloured BLACK.
- The wire which is coloured BROWN must be connected to the terminal which is marked with the letter (L) or coloured RED.

If in doubt regarding the electrical connection of this appliance, consult a qualified electrician. Do not shorten the supply cable, the appliance may require removing for servicing.

N.B. Ensure that the plug socket is situated in an easily accessible place after installation.

Changing the lamp bulb

This appliance is fitted with a long life LED lamp that should serve you for the lifespan of the product. However, should the need arise to change or replace the bulb in your fridge, please contact CDA Customer Care to arrange a service visit using the details below.

Contact CDA Customer Care

A: Customer Care Department, The CDA Group Ltd, Harby Road,
Langar, Nottinghamshire, NG13 9HY

T: 01949 862 012 **F:** 01949 862 003

E: customer.care@cda.eu **W:** www.cda.eu

When contacting CDA Customer Care please have your model and serial numbers to hand. You can use page 3 of this manual to note these down if you wish.

In the event of a service call within your warranty period, please have your proof of purchase, such as an invoice or receipt, to hand.

Please note: The full warranty will only be applicable provided you have registered your appliance with CDA within 30 days of the purchase date.

Energy Efficiency Information

Attribute	Symbol	Value	Units
Model identification		MFU251	
Category of the household refrigerating appliance		7	
Voltage / Frequency		220 - 240V ~ / 50Hz	
Dimensions (W x D x H cm)		596 x 550 x 818-870	
Mass of the appliance	M	32.5	kg
Energy efficiency class		A+	
Annual energy consumption	A _{Ec}	173	kWh/year
The energy consumption is based on standard test results for 24 hours. Actual energy consumption will depend on how the appliance is used and where it is located.			
Storage volume (fridge)		96	L
Storage volume (freezer)		16	L
Star rating			°C
Defrosting type		Fridge automatic, icebox manual.	
Climate class		N-ST	
Airborne acoustic noise emissions	pW	41	dB(A)



Serviced by



Built for your life

For our Customer Care Department, or for Service,
please contact us on: